



**OMICRON**

# CMC 256plus

## User Manual



**Article Number VESD2002 - Version CMC256plus.AE.6**

© OMICRON electronics. All rights reserved.

This manual is a publication of OMICRON electronics.

All rights including translation reserved. Reproduction of any kind, e.g., photocopying, microfilming, optical character recognition and/or storage in electronic data processing systems, requires the explicit consent of OMICRON electronics.

Reprinting, wholly or in part, is not permitted. The product information, specifications, and technical data embodied in this manual represent the technical status at the time of writing and are subject to change without prior notice.

We have done our best to ensure that the information given in this manual is useful, accurate and entirely reliable. However, OMICRON electronics does not assume responsibility for any inaccuracies which may be present.

The user is responsible for every application that makes use of an OMICRON product.

OMICRON electronics translates this manual from the source language English into a number of other languages. Any translation of this manual is done for local requirements, and in the event of a dispute between the English and a non-English version, the English version of this manual shall govern.

# TABLE OF CONTENTS

<b>Preface</b> .....	<b>7</b>
<b>Safety Instructions</b> .....	<b>8</b>
<b>1 Designated Use</b> .....	<b>11</b>
<b>2 Introduction</b> .....	<b>12</b>
2.1 Options Available for the CMC 256 Test Set.....	12
<b>3 Operating the CMC 256</b> .....	<b>13</b>
3.1 System Components .....	13
3.2 Safe Use of the Connecting Cables .....	14
3.2.1 Test Lead Adapter for Non-Safety Sockets .....	14
3.2.2 Regular Test Leads for Safety Sockets .....	15
3.2.3 Terminal adapters.....	15
3.2.4 M4 (0.15") Cable Lug Adapters .....	16
3.2.5 M5 (0.20") Cable Lug Adapters .....	16
3.3 Starting the Test System .....	17
<b>4 Setup and Function</b> .....	<b>19</b>
4.1 Block Diagram .....	20
4.1.1 Voltage Output (Voltage Amplifier) .....	21
4.1.2 Current Output (Current Amplifier).....	22
4.1.3 Binary / Analog Input (Binary Inputs 1 – 10).....	23
4.1.4 Binary / Analog Input (Analog Inputs 1 – 10).....	23
4.1.5 Analog DC Input (UDC, IDC).....	25
4.1.6 Binary Output.....	25
4.1.7 AUX DC (DC Power for Test Objects) .....	26
4.1.8 CPU .....	27
4.1.9 Power Supplies (DC-DC).....	27
4.2 Signal Generation.....	28
4.2.1 Accuracy and Signal Quality .....	28

<b>5</b>	<b>Connections and Interfaces .....</b>	<b>29</b>
5.1	Front Panel Connections .....	29
5.1.1	Generator Combination Socket for VOLTAGE OUTPUT and CURRENT OUTPUT .....	32
5.2	Connections on the Back Panel .....	34
5.2.1	Ethernet Ports ETH1 and ETH2 .....	34
5.2.2	! Button .....	35
5.2.3	Associate Button .....	35
5.2.4	Status LED A, B .....	36
5.2.5	Ethernet / Network Settings .....	36
5.2.6	SELV Interfaces .....	38
5.2.6.1	External Interface ("ext. Interf.") .....	38
5.2.6.2	LL out 1-6 (Low Level Outputs 1-6) .....	39
5.2.6.3	LL out 7-12 (Low Level Outputs 7-12) - Option "LLO-2" .....	39
<b>6</b>	<b>Technical Data .....</b>	<b>41</b>
6.1	Main Power Supply .....	41
6.2	Insulation Coordination .....	42
6.3	Outputs .....	43
6.3.1	Extended Frequency Range .....	44
6.3.2	CURRENT OUTPUT A and B .....	45
6.3.2.1	Typical Duty Cycles for Different Loads and Output Configurations ..	46
6.3.2.2	Ensuring continuous operation .....	54
6.3.3	Parallel Switching of CURRENT OUTPUT A and B .....	55
6.3.4	Single-phase Operation for Output Currents .....	56
6.3.5	Voltage Outputs .....	58
6.3.5.1	Power Diagram for Three-Phase Operation .....	59
6.3.5.2	Power Diagram for Single-Phase Operation .....	60
6.3.6	Accuracy of Output Power .....	61
6.3.7	Operational Limits in Conjunction with a Weak Mains Supply Voltage .....	61
6.3.8	Low Level Outputs "LL out" for External Amplifiers .....	62
6.3.9	Low-Level Binary Outputs ("ext. Interf.") .....	64
6.3.10	Binary Output Relays .....	66
6.3.11	DC Supply (AUX DC) .....	67
6.4	Inputs .....	68
6.4.1	Binary Inputs .....	68
6.4.2	Counter Inputs 100 kHz (Low Level) .....	71
6.4.3	DC Measurement Inputs (ANALOG DC INPUT) .....	73

6.5	Technical Data of the Ethernet Ports.....	74
6.5.1	The NET-1B Board .....	74
6.5.2	The NET-1 Board.....	75
6.6	Environmental Conditions.....	76
6.6.1	Climate.....	76
6.6.2	Shock and Vibration.....	76
6.7	Mechanical Data.....	76
6.8	Cleaning .....	76
6.9	Safety Standards, Electromagnetic Compatibility (EMC) and Certificates .....	77
6.10	The EnerLyzer Measurement Option .....	78
6.10.1	General Data .....	79
6.10.2	Multimeter Mode .....	79
6.10.2.1	Accuracy AC Measurements .....	80
6.10.2.2	Channel Cross-Talk.....	83
6.10.2.3	Accuracy Phase Measurement.....	84
6.10.2.4	Accuracy of the Frequency Measurement.....	86
6.10.2.5	Accuracy of Power Measurement.....	87
6.10.3	Harmonic Analysis .....	91
6.10.3.1	Accuracy of the Frequency Measurement.....	92
6.10.3.2	Accuracy Amplitude Measurement.....	93
6.10.3.3	Accuracy of Phase Measurement.....	94
6.10.4	Transient Recording .....	95
6.10.5	Trend Recording .....	96
6.11	The PAR-1 Option (CMC 256 with Parallel Port).....	97
6.12	The LLO-2 Option (Low Level Outputs).....	98
<b>7</b>	<b>Increasing the Output Power .....</b>	<b>99</b>
7.1	1 x 0 ... 12.5 A .....	100
7.2	1 x 0 ... 37.5 A .....	101
7.3	1 x 0 ... 75 A .....	103
7.4	2 x 0 ... 37.5 A .....	105
7.5	3 x 0 ... 25 A .....	106
7.6	Single-Phase Voltage .....	107
7.7	Operation with External Amplifiers .....	108

<b>8</b>	<b>Troubleshooting .....</b>	<b>109</b>
8.1	Troubleshooting Guide .....	109
8.2	Potential Errors, Possible Causes, Remedies.....	110
8.3	Overheating.....	111
<b>9</b>	<b>CMC 256-Related Products and Accessories .....</b>	<b>113</b>
9.1	CMA Current Amplifiers & CMS Voltage Amplifiers .....	113
9.2	CMControl-6 .....	114
9.3	CMB IO-7.....	115
9.4	CMUSB-P Converter .....	117
9.5	Time Synchronization Accessories.....	118
9.5.1	CMGPS.....	118
9.5.2	CMIRIG-B .....	120
9.6	100TX to 100FX-SC Converter .....	122
9.7	Current Clamp C-PROBE1 .....	123
9.8	Accessories for Meter Testing .....	124
9.8.1	Scanning Head OSH256 .....	124
9.8.2	Interface Box IFB256 .....	125
9.8.3	Scanning Head TK 326.....	126
9.8.4	Scanning Head TVS 6.15/1 .....	127
9.8.5	Adapter Cable for Scanning Heads .....	128
9.8.6	CMLIB B .....	129
9.8.7	CMLIB A .....	130
9.8.8	CPOL Polarity Tester.....	131
9.8.9	Connection Cable for REF 54x Relays (ABB) with Low Level Signal Inputs ...	132
9.8.10	C-Shunt.....	133
9.9	Wiring Accessories .....	134
9.9.1	Standard Delivery Scope .....	134
9.9.2	Optional CMC Wiring Accessory Package .....	135
9.10	Ordering Information.....	138
	<b>Appendix .....</b>	<b>145</b>
	The OMICRON Bootloader software .....	145
	<b>Contact Information / Technical Support .....</b>	<b>149</b>
	<b>Index .....</b>	<b>151</b>

## PREFACE

The purpose of this reference manual is to familiarize users with the *CMC 256plus* test set and to show how to properly use it in various application areas.

The manual contains important tips on how to use the *CMC 256plus* safely, properly, and efficiently. Its purpose is to help you avoid danger, repair costs, and down time as well as to help maintain the reliability and life of the *CMC 256plus*.

This manual is to be supplemented by existing national safety standards for accident prevention and environmental protection.

The reference manual should always be available at the site where the *CMC 256plus* is used. It should be read by all personnel operating the test set.

**Note:** The OMICRON *Test Universe* software also installs a PDF version of this reference manual. It can directly be opened by a mouse-click from the help topic "User Manuals of OMICRON Test Universe".

In addition to the reference manual and the applicable safety regulations in the country and at the site of operation, the usual technical procedures for safe and competent work should be heeded.

**Note:** This reference manual describes the *CMC 256plus* hardware - that is, the physical test set. In order to get familiar with the software for controlling and configuring the *CMC 256plus*, please refer to the software manuals and/or the OMICRON *Test Universe* Help.

### Convention:

For the sake of readability, this reference manual uses the abbreviation "*CMC 256*" to refer to the *CMC 256plus* test set

## For Your Safety Please Note

The *CMC 256plus* test set can output life-hazardous voltages and currents.



Throughout the manual, this symbol indicates special safety-relevant notes/directions linked to the possibility of touching live voltages and/or currents. Please thoroughly read and follow those directions to avoid life-hazardous situations.



This symbol indicates potential hazards by electrical voltages/currents caused by, for example, wrong connections, short-circuits, technically inadequate or faulty equipment or by disregarding the safety notes of the following sections.

## SAFETY INSTRUCTIONS



Before operating the *CMC 256* test set, carefully read the following safety instructions.

Only operate (or even turn on) the *CMC 256* after you have read this reference manual and fully understood the instructions herein.

*The CMC 256 may only be operated by trained personnel. Any maloperation can result in damage to property or persons.*

### Rules for Use

- The *CMC 256* should only be used when in a technically sound condition. Its use should be in accordance with the safety regulations for the specific job site and application. Always be aware of the dangers of the high voltages and currents associated with this equipment. Pay attention to the information provided in the reference manual and the software documentation.
- The *CMC 256* is exclusively intended for the application areas specified in section 1, "Designated Use" on page 11. The manufacturer/distributors are not liable for damage resulting from unintended usage. The user alone assumes all responsibility and risk.
- The instructions provided in this reference manual and the associated software manuals are considered part of the rules governing proper usage.
- Do not open the *CMC 256* or remove any of its housing components.

### Orderly Practices and Procedures

- The reference manual (or its "electronic PDF pendant", which is installed to your computer with the OMICRON Test Universe software) should always be available on site where the *CMC 256* is used.



**Note:** The OMICRON *Test Universe* software also installs a PDF version of this reference manual. It can directly be opened by a mouse-click from the help topic "User Manuals of OMICRON Test Universe". The *Test Universe* Help can be launched by clicking **Help** on the *Start Page*.


- Personnel assigned to using the *CMC 256* must have read this reference manual and fully understood the instructions herein.
- Do not carry out any modifications, extensions or adaptations at the *CMC 256*.



## Operator Qualifications

- Testing with the *CMC 256* should only be carried out by authorized and qualified personnel.
- Personnel receiving training, instruction, direction, or education on the *CMC 256* should remain under the constant supervision of an experienced operator while working with the equipment.

## Safe Operation Procedures

- Follow the instructions in sections 3.2 and 3.3 that describe the safe use of the connecting cables and how to set the *CMC 256* into operation.
- *CMC 256* must only be used from a power outlet that has a protective earth.
- Do not block the access to safety-relevant test set components like the main power switch or the power cord. In cases of an emergency, these components need free and quick access.
- Do not connect any of the front panel VOLTAGE/CURRENT OUTPUTS 1 ... 3 or VOLTAGE OUTPUT 4, respectively, to protective earth. The N sockets, however, may be connected to protective earth.
- When connecting to the banana plug sockets, only use cables with 4 mm/0.16 " safety banana connectors and plastic housing. Always insert plugs completely.
- Before connecting and disconnecting test objects, verify that all outputs have been turned off. Never connect or disconnect a test object while the outputs are active.
- When disconnecting power supply cables or test leads, always start from the device feeding the power or signal.
- All sockets on the front panel are to be considered dangerous with working voltages up to 300 V<sub>rms</sub>. Only use cables that meet these respective requirements to connect to the equipment.
- Red Signal Light :
 

If the voltage on any of the four voltage outputs or on the "AUX DC" output exceeds 42 V, the associated signal light lights up.
- Do not insert objects (e.g., screwdrivers, etc.) into the sockets or into the ventilation slots.
- Do not operate the *CMC 256* under wet or moist conditions (condensation).

- Do not operate the *CMC 256* when explosive gas or vapors are present.
- The SELV-interface (SELV = Safety Extra Low Voltage) of the *CMC 256* - "Host Interf." or "ETH1", "LL out" (Low Level Outputs), "ext. Interf." - should only have external devices connected that meet the requirements for SELV equipment according to EN 60950 or IEC 60950.
- For applications with DC current: The load may not exceed 3 mH because of dangerous feedback current.
- When setting up the *CMC 256*, make sure that the air slots on the back, top, and bottom of the test set remain unobstructed.
- Voltages up to 1 kV can be present inside the *CMC 256*! Therefore, opening the *CMC 256* is only permitted by qualified experts either at the factory or at certified external repair centers.
- If the *CMC 256* is opened by the customer, all guarantees are invalidated.
- *CMC 256* Ethernet functionality (see section 5.2.1, "Ethernet Ports ETH1 and ETH2" on page 34):
  - It is a product of laser class 1 (EN 60825, IEC 60825).
  - Connect ETH1 **only** to Ethernet ports.
- If the *CMC 256* seems to be functioning improperly, please contact the OMICRON Technical Support (see section "Contact Information / Technical Support" on page 149).

## Changing the Power Fuse

- Unplug the power cord between the test set and the power source.
- The fuse is located at the back of the test set.
- Fuse type: **T12.5 AH 250 V** (wire fuse 5 × 20 mm).

For safety reasons please use only fuse types recommended by the manufacturer. Refer to 6.1, "Main Power Supply" on page 41 for more information.

# 1 DESIGNATED USE

The *CMC 256* is a computer-controlled test set for the testing of:

- protection relays
- transducers
- energy meters
- PQ (power quality) analyzers.

In addition to the test functions, optional high-performance measurement functions [0 Hz (DC) ... 10 kHz] for ten analog inputs are available.

The *CMC 256* is part of the OMICRON *Test Universe* which, in addition to the physical test set, consists of a test software for a computer with Windows<sup>1</sup> operating system, and, when needed, external voltage and/or current amplifiers, GPS or IRIG-B synchronization units or other accessories.

## Features of the CMC 256plus:

- Output of test quantities:
  - 4 × voltage
  - two galvanically separated current triples.
- Control of external amplifiers (up to 12 additional test signals) through the low-level interface.
- Supply of DC voltages to the test object.
- Output of binary signals.
- Capture of signals, counter impulses, and DC measured values.
- Option *EnerLyzer*: Measurement and analysis of DC and AC voltages, as well as DC and AC currents by means of a clip-on probe (refer to section 6.10, "The EnerLyzer Measurement Option" on page 78).

Any other use of the *CMC 256* is considered improper and may result in damage to property or persons.

---

<sup>1</sup> Windows is a US registered trademark of Microsoft Corporation.

## 2 INTRODUCTION

The *CMC 256* is a part of the *OMICRON Test Universe* which, in addition to the physical test set, consists of a test software for a computer with Microsoft Windows operating system, and, when needed, external voltage and/or current amplifiers, GPS or IRIG-B synchronization units or other accessories (refer to section 9, "CMC 256-Related Products and Accessories" on page 113).

This reference manual describes the hardware of the *CMC 256*. The configuration and control of the *CMC 256* is carried out by the test software of the *OMICRON Test Universe*. For more detailed information, please read the user manuals and the *OMICRON Test Universe* Help.



**Note:** The *OMICRON Test Universe* software also installs a PDF version of this reference manual. It can directly be opened by a mouse-click from the *OMICRON Test Universe* Help topic "User Manuals".

### 2.1 Options Available for the CMC 256 Test Set

The following options are available for the *CMC 256* test set:

- *EnerLyzer*  
Software module for measuring and analyzing AC and DC voltages (refer to section 6.10, "The EnerLyzer Measurement Option" on page 78).
- **LLO-2** (low level outputs 7-12)  
SELV interface connector holding two independent generator triples (SELV = Safety Extra Low Voltage). These six additional high accuracy analog signal sources can serve to either control an external amplifier or to directly provide small signal outputs.  
For more information please refer section 6.3.8, "Low Level Outputs "LL out" for External Amplifiers" on page 62.
- **PAR-1** (*CMC 256* with **parallel** port)  
Also refer to section 6.11, "The PAR-1 Option (*CMC 256* with Parallel Port)" on page 97.  
The *CMC 256* with a parallel port, replacing the two Ethernet ports. Option PAR-1 is used, for example, in conjunction with the *OMICRON CMB IO-7*.  
The *CMB IO-7* is a computer-controlled extension unit used for applications where the number of available binary inputs and outputs of a *CMC* test set is not sufficient. The binary inputs and outputs of *CMB IO-7* can be used as an equivalent extension.

- **FL-6**

In a number of countries (e.g., Japan), the export of multiphase generators able to output steady signals with a frequency between 600 Hz and 2000 Hz is not permitted.

The **FL-6** option constraints the maximum fundamental frequency that the test set can generate to 599 Hz. Test sets with the FL-6 option can therefore be exported without any restrictions (refer to 6.3, "Outputs" on page 43).

## 3 OPERATING THE CMC 256



Only operate (or even turn on) the *CMC 256* after you have read this reference manual and fully understood the instructions herein.

### 3.1 System Components

Before operating the *CMC 256* for the first time, use the packing list to verify that all components of the test system are available.

To set the *CMC 256* into operation you need the following components:

- *CMC 256* with (mains) power cable.
- Connecting cable *CMC 256* ↔ computer.
- Connecting cable(s) *CMC 256* ↔ test object.
- A computer equipped with the OMICRON *Test Universe* software.

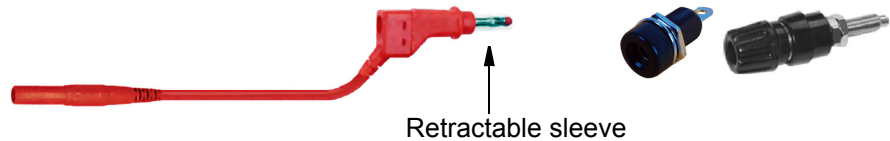
To communicate with a standard *CMC 256*, this computer needs an Ethernet port (see also section 5.2.1, "Ethernet Ports ETH1 and ETH2" on page 34).

To communicate with a *CMC 256* with PAR-1 option, this computer needs either a parallel printer port or an USB port plus a *CMUSB-P* converter (see 9.4, "CMUSB-P Converter" on page 117).

## 3.2 Safe Use of the Connecting Cables

### 3.2.1 Test Lead Adapter for Non-Safety Sockets

The optional CMC Wiring Accessory Package includes flexible test lead adapters of 5 cm/2 " length with a retractable sleeve (6 x black, 6 x red).

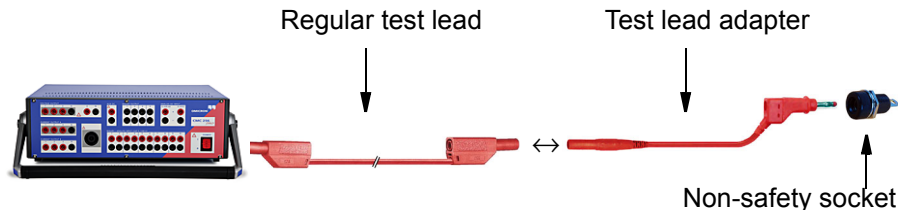


These test leads are to be used as **adapters**, only. They are intended to make the 4 mm/0.16 " banana plugs of the standard test leads fit into non-safety sockets (see illustration above).

**Never directly insert one of these retractable sleeves into a CMC 256 output socket at the front of the test set.** This does not comply with the designated purpose of these leads and is contrary to the safety regulations.

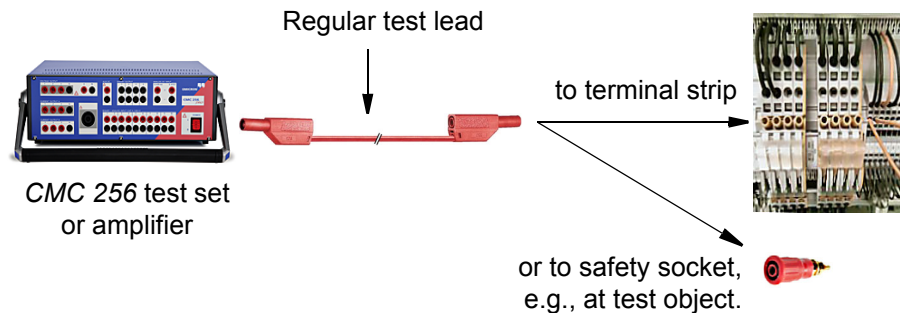


Plug **only the regular test leads** of 2.0 m/6 ft. length into the CMC 256 output safety sockets.



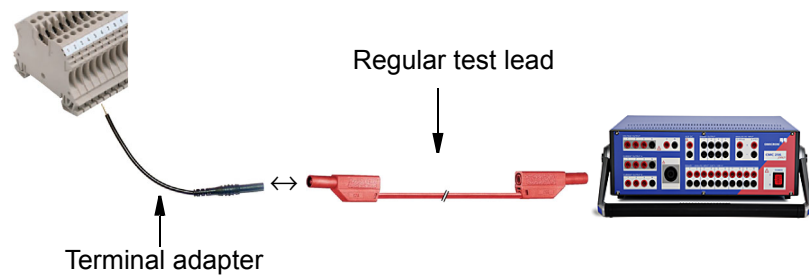
### 3.2.2 Regular Test Leads for Safety Sockets

Use the regular test leads of 2.0 m/6 ft. length to connect the *CMC 256* output to other safety sockets of, for example, amplifiers, test objects or to banana adapters in control cabinets.



### 3.2.3 Terminal adapters

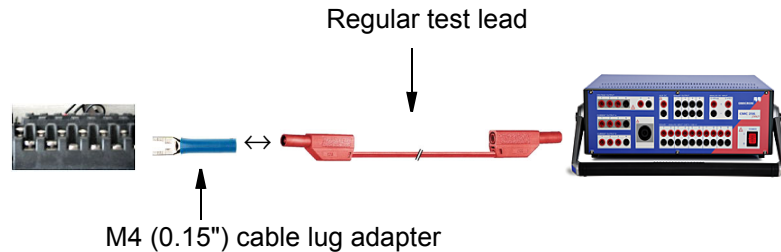
The optional CMC Wiring Accessory Package includes flexible terminal adapters to connect the regular test leads to screw-clamp terminals.



The terminal adapters have blank ends. Therefore, turn off the voltage before connecting these adapters. Always insert an adapter with its blank end into the terminal strip first, and fasten it, before connecting it to a test lead.

### 3.2.4 M4 (0.15") Cable Lug Adapters

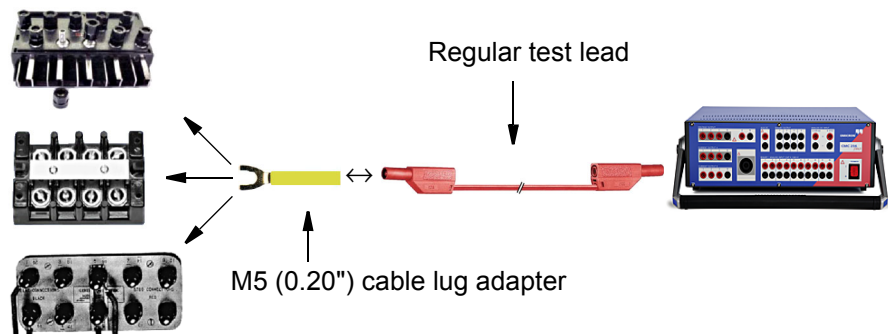
The optional CMC Wiring Accessory Package includes M4 (0.15") cable lug adapters to connect regular test leads to screw-clamp terminals of SEL/ABB/GE relays (and others).



The cable lugs have blank ends. Therefore, turn off the voltage before connecting such a lug. Always insert the cable lug with its blank end into the terminal strip first, and fasten it, before connecting it to a test lead.

### 3.2.5 M5 (0.20") Cable Lug Adapters

The optional CMC Wiring Accessory Package includes M5 (0.20") cable lug adapters to connect regular test leads to common and most widespread screw-clamp terminal types.



The cable lugs have blank ends. Therefore, turn off the voltage before connecting such a lug. Always insert the cable lug with its blank end into the terminal strip first, and fasten it, before connecting it to a test lead.



### 3.3 Starting the Test System

The following description assumes that the PC has been set up and that the test software for the OMICRON *Test Universe* has been installed.

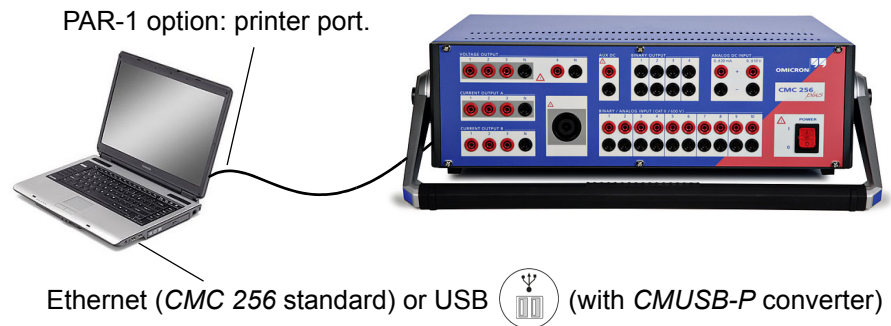
If the system is driven by external amplifiers, follow the instructions in section 7.7, "Operation with External Amplifiers" on page 108.



When setting up the *CMC 256*, make sure that the ventilation slots remain unobstructed.

#### Connecting the system components:

Figure 3-1:  
Connecting the  
*CMC 256* to the PC



1. Connect the *CMC 256* to the PC with the supplied connecting cable<sup>1</sup>:
  - *CMC 256* standard: Ethernet connector ETH1 at the rear side of the test set.
  - *CMC 256* with PAR-1 option: parallel connector "Host Interf." at the rear side of the test set.
  - Computer: to connect to a standard *CMC 256*, use the Ethernet port (labeled "EtherNET", "LAN" or similar).
  - If it's a *CMC 256* with PAR-1 option, use the computer's printer port (labeled "PRT", "Printer" or "LPT1") or alternatively an USB port via a *CMUSB-P* converter (see also 9.5.2, "CMIRIG-B" on page 120).



For instructions to help you to incorporate network-capable CMC test sets like the *CMC 256* into a computer network, refer to the manual "Network-based CMC Test Sets". This manual is provided as PDF file; its name is **Network-based test sets.pdf**. It is available on your hard disk at

***Test Universe installation folder\Test Universe\Doc\.***

<sup>1</sup> To ensure the required EMC compatibility, we recommended to use the OMICRON-supplied cable, only.

2. Connect the *CMC 256* test set to the mains.
3. Turn on both devices.
4. Start the OMICRON *Test Universe* software.

A comprehensive hardware test is carried out on the *CMC 256*. In the process, switching sounds from relays in the CMC test set can be heard. If any irregularities are determined during the course of this self-test, the software displays a corresponding error message on the PC monitor (refer to section 8, "Troubleshooting" on page 109).

## 4 SETUP AND FUNCTION

The computer-controlled OMICRON test system employs the concept of a functional division between the software running on the computer and the *CMC 256* hardware connected to the test object.

### **OMICRON *Test Universe* test software running on the computer**

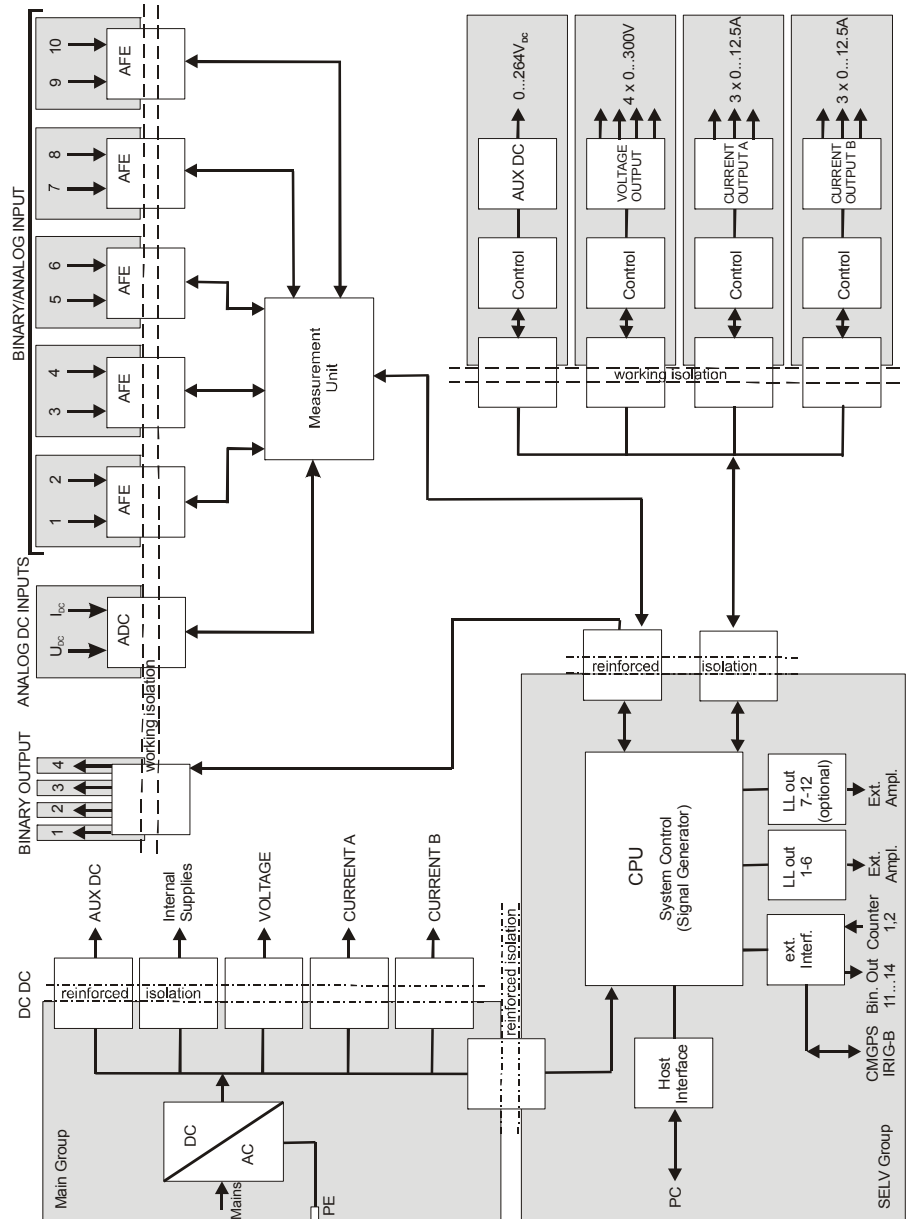
- controls the test signals
- processes measurement data
- creates reports
- generates data entries.

### **The *CMC 256* test set**

- creates test signals (currents, voltages, binary signals)
- measures the reaction (analog and binary) from the test object
- supplies DC-current to test objects.

## 4.1 Block Diagram

Figure 4-1:  
Main block diagram of the  
CMC 256

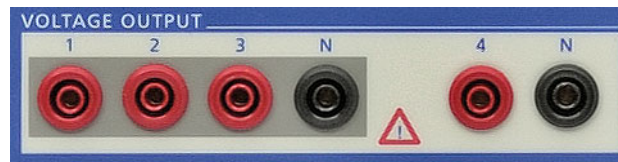


The block schematic diagram in figure 4-1 shows all externally accessible signals with gray shading. Every gray area represents a galvanic group that is isolated from all of the other galvanic groups.

The power connection ("power supply group") and the connections for "SELV group" (SELV = Safety Extra Low Voltage) are available on the back of the test set. All other gray shaded groups are available on the front of the test set. The safety relevant isolated circuits (power ↔ SELV, power ↔ front plate, and front plate ↔ SELV) are marked as "reinforced isolation" in the block diagram.

### 4.1.1 Voltage Output (Voltage Amplifier)

Figure 4-2:  
Voltage amplifier  
(voltage outputs)



The four voltage outputs have a common neutral N and are galvanically separated from all other outputs of the CMC 256. The two black sockets labeled "N" are galvanically connected with one another.

The voltage amplifier and the current amplifiers are linear amplifiers with DC coupling. The voltage outputs work in two ranges:

- Range 1: 4 x 0 ... 150 V
- Range 2: 4 x 0 ... 300 V

#### Protecting the Voltage Outputs

All voltage outputs are protected for open circuits, L-N short-circuits, and overload. Should the heat sink overheat, a thermal switch turns off all outputs.

#### Overload Warning Flagged in the Software

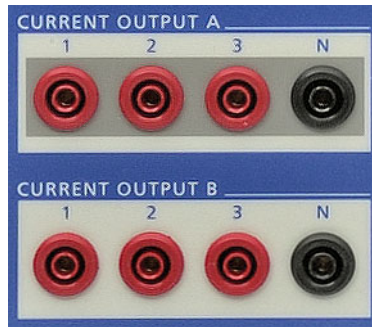
When a voltage output is overloaded, a corresponding warning is displayed in the user interface of the test software of the OMICRON *Test Universe* (like described in, for example, section 8.3, "Overheating" on page 111).



Do not connect any of the VOLTAGE OUTPUTS 1 ... 3 or VOLTAGE OUTPUT 4, respectively, to protective earth. The N sockets, however, may be connected to protective earth.

## 4.1.2 Current Output (Current Amplifier)

Figure 4-3:  
CMC 256 current outputs  
groups A & B



### CURRENT OUTPUT A

### CURRENT OUTPUT B

Two galvanically separated three-phase current outputs, each with their own neutral (N).

Each output is galvanically separated from all other connections of the CMC 256.

The current amplifiers are implemented as switched mode amplifiers with DC coupling. With this technology it is possible to achieve high power density in a very compact structure. The DC coupling enables a precise reproduction of transients or DC offsets.

All current outputs are equipped with two current ranges in order to increase their dynamic ranges:

- Range 1:  $6 \times 1.25 \text{ A}$
- Range 2:  $6 \times 12.5 \text{ A}$

### Protecting the Current Outputs

All current outputs are protected for open circuits, short-circuits, and overloads. If the heat sink overheats, a thermo switch turns off all outputs.

In non-operative state, relay contacts (as illustrated in figure 5-3) protect the current amplifier from external power by shortening the outputs to N.



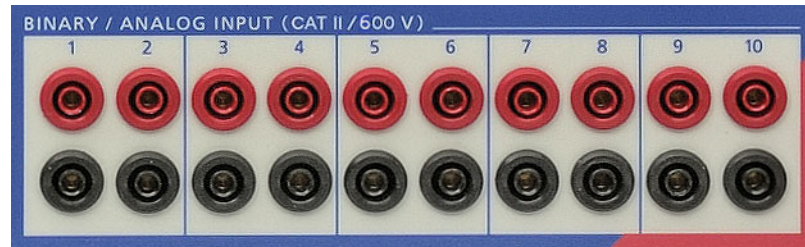
**Caution:** If there is an in-feed from an external source, the current outputs can be damaged or destroyed.

### Overload Warning Flagged in the Software

When a current output is overloaded, a corresponding warning is displayed in the user interface of the test software of the OMICRON *Test Universe* (like described in, for example, section 8.3, "Overheating" on page 111).

### 4.1.3 Binary / Analog Input (Binary Inputs 1 – 10)

Figure 4-4:  
Binary/analog inputs 1 - 10



The ten binary inputs are divided into five groups of two, each group galvanically separated from the others.

The input signals are monitored using an isolation amplifier with a time resolution of 100  $\mu$ s and are then evaluated in the measurement units.

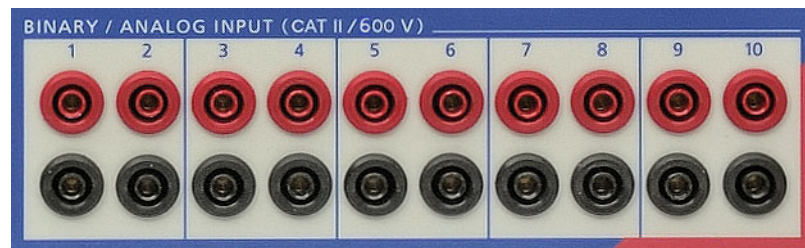
The binary inputs are configured from the hardware configuration module of the OMICRON *Test Universe* software. When doing so, it can be specified whether the contacts are potential-sensitive or not. When the contacts are potential-sensitive, the expected nominal voltage and pick-up threshold can be set for each binary input.

Moreover, the binary inputs 1 – 10 can be used as counter inputs for input frequencies up to 3 kHz.

More detailed information about the configuration of the binary inputs can be found in the OMICRON *Test Universe* Help.

### 4.1.4 Binary / Analog Input (Analog Inputs 1 – 10)

Figure 4-5:  
Measurement unit  
(analog inputs 1 – 10)



All ten of the binary inputs to the CMC 256 can be individually configured through the software as being binary or analog measurement inputs<sup>1</sup>.

<sup>1</sup> Up to three inputs can be used for measuring rms values without the *EnerLyzer* option.

Setting the inputs to be analog measurement inputs can be accomplished using the measurement option *EnerLyzer*. This *EnerLyzer* option can be upgraded at any later stage (refer to section 6.10, "The EnerLyzer Measurement Option" on page 78).

The capture of measurement values with range switching from each two channels occurs in an analog input stage AFE (Analog Front End), which is galvanically separated from the other input stages.

The input signals 1 - 10 can be captured in a frequency range from 0 Hz (DC) to approximately 10 kHz. The sampling rate can be switched between three predefined values (refer to table 6-29 on page 80).

The measured values are passed through an isolation amplifier to the "Measurement Unit" and are digitized with an A/D converter. Further processing occurs through a high-performance floating point digital signal processor (DSP).

As such, apparent power, reactive power, active power, etc., can be provided in real-time and transmitted to the PC.

The inputs are implemented as voltage inputs and have five measurement ranges: 100 mV, 1 V, 10 V, 100 V, and 600 V. The inputs are protected in each measurement range up to the input voltage of 600 V<sub>rms</sub>.

For measuring current a current clamp is used, such as 10 mV/A for currents up to 80 A (refer to section 9.7, "Current Clamp C-PROBE1" on page 123). When measuring with the current clamp, the current measurement channel is additionally galvanically separated from the adjacent measurement channel. The accuracy of the current measurement is mainly limited by the accuracy of the current clamp.

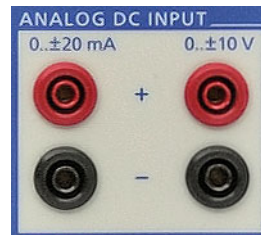
In addition to the synchronous capture of 10 measurement channels, the *EnerLyzer* option offers mathematically combining and evaluating of measurement channels in order to achieve:

- Evaluation of DC components (DC voltages or DC currents)
- Effective values (true RMS) of all measurement signals in real-time
- Peak values ( $U_{peak}$ ,  $I_{peak}$ , ...)
- Phase angles with reference to a given input signal
- Calculation of apparent, reactive, and active power (in any configuration) in real-time
- Frequency and spectrum (harmonic diagrams) of periodic signals
- Capture of transient input signals at various sampling rates
- Different triggering options for the capture of transient signals



### 4.1.5 Analog DC Input ( $U_{DC}$ , $I_{DC}$ )

Figure 4-6:  
Measurement unit  
DC Input  
(analog inputs  $V_{DC}$ ,  $I_{DC}$ )



The measurement of analog DC signals is implemented for the testing of transducers and consists of:

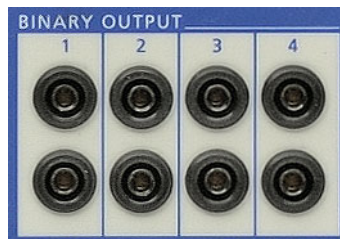
- a high accuracy voltage reference
- an ADC (**A**nalog **D**igital **C**onverter) for each input
- the respective input circuits (i.e., accuracy voltage divider, shunt, filter).

The input signals  $U_{DC}$  and  $I_{DC}$  are measured. The  $I_{DC}$  input has two ranges available:  $0 \dots \pm 20 \text{ mA}$  and  $0 \dots \pm 1 \text{ mA}$ . A reversible input fuse is used as protection to the  $I_{DC}$  input.

The evaluation and forwarding of the measurement values takes place in the measurement unit.  $U_{DC}$  and  $I_{DC}$  inputs reference a common neutral N. The DC measurement unit is galvanically separated from all connections on the front panel.

### 4.1.6 Binary Output

Figure 4-7:  
Binary outputs



Four binary outputs are available for use as potential-free relay contacts.

More detailed information about the configuration of the binary outputs can be found in the *OMICRON Test Universe Help*.

### 4.1.7 AUX DC (DC Power for Test Objects)

Figure 4-8:  
DC power for test objects  
(AUX DC)



Test objects that require an auxiliary DC voltage can be fed from the AUX DC output.

The DC voltage that is applied over the AUX DC output can vary from 0 to 264 Volts and is configured using the software.

The AUX DC output is galvanically separated from all other outputs.

#### The power-up default

By means of the test tool *AuxDC* you can set a so-called power-up default. When the test set is powered-up the next time, the auxiliary DC output is automatically set to this default value. This default value applies until it is deliberately changed again.

Setting a power-up default value means, that immediately after the test set is switched on, this voltage is applied to the auxiliary DC voltage output, regardless whether a computer is connected to it or not.

#### Caution: The selected voltage can be life-threatening!

Consider storing a power-up default voltage of higher than 0 V a potential danger to future users that may connect other devices to this CMC test set. We strongly recommend to always set the default value to 0 V before storing the device, or to otherwise attach a warning label to the device housing, such as "*This unit outputs an AuxDC voltage of \_\_\_ V immediately after powering-up*".



If the voltage on the "AUX DC" output exceeds 42 V, the associated signal light lights up.

More information about the configuration of the AUX DC supply can be found in the OMICRON *Test Universe AuxDC* Help.



#### 4.1.8 CPU

The *CMC 256* CPU (**C**entral **P**rocessing **U**nit) out the following tasks:

- Communication with the computer or a network via the Ethernet ports "ETH1" and "ETH2".

Optionally, communication with the computer via the parallel interface "Host Interf" (option PAR-1; refer to 6.11, "The PAR-1 Option (*CMC 256* with Parallel Port)" on page 97).

- Digital signal generation for all outputs of the test set (including control signals for external amplifiers).
- Generation of a high-accuracy central clock signal with synchronization options using the *CMGPS* synchronization unit or the *CMIRIG-B* interface box (refer to 9.5, "Time Synchronization Accessories" on page 118).
- Monitoring and control of all systems, including external amplifiers, if applicable.

#### 4.1.9 Power Supplies (DC-DC)

An AC/DC converter generates the required DC voltage from 85 to 264 V<sub>AC</sub> supply voltage (see section 6.1) and ensures adequate EMC filtering.

The power supply to the different modules, that each are part of their own galvanic groups, are implemented using DC-DC converters with reinforced insulation.

## 4.2 Signal Generation

The generation of sine wave signals with high amplitude and phase accuracy is required in order to achieve output signals with the specified accuracy.

In order to fulfill the requirement for phase-coupled signal sources, signal generation is digitally implemented.

For this, the *CMC 256* employs a high-performance digital signal processor (DSP).

With digital signal generation the system is very flexible. An exact correction of the amplitude, offset, and phase can be carried out in a digital manner through the use of device-specific parameters (i.e., gain, offset, and null phase angle on every channel).

The digital correction assures the best possible long-term drift behavior.

In addition to sine waves, any other periodic or transient signal can be generated.

### 4.2.1 Accuracy and Signal Quality

The *CMC 256* is a very precise test set with excellent long-term and temperature drift behavior. In addition to the high amplitude accuracy, the *CMC 256* is especially noted for the phase accuracy.

To achieve this accuracy, the philosophy was not only to solve signal generation digitally, but also to implement the distribution of signals to the various modules using digital methods. In doing so, the goal of galvanic separation of the individual generator groups was also achieved without loss of accuracy.

In achieving the amplitude accuracy, the drift behavior (temperature and long-term) is of major importance in the voltage references, the digital-analog converters (DAC), the accurate voltage dividers in the voltage amplifiers, and the current shunts in the current amplifiers.

The actual (typical) data is in general about a factor of 3 better than the guaranteed data.

The associated exact measurement media are required for the assurance of the accuracy in the production. The measurement media used by OMICRON are regularly calibrated by an accredited calibration institute so that tracing to international standards can be assured.

## 5 CONNECTIONS AND INTERFACES

### 5.1 Front Panel Connections

Figure 5-1:  
Front view of the CMC 256

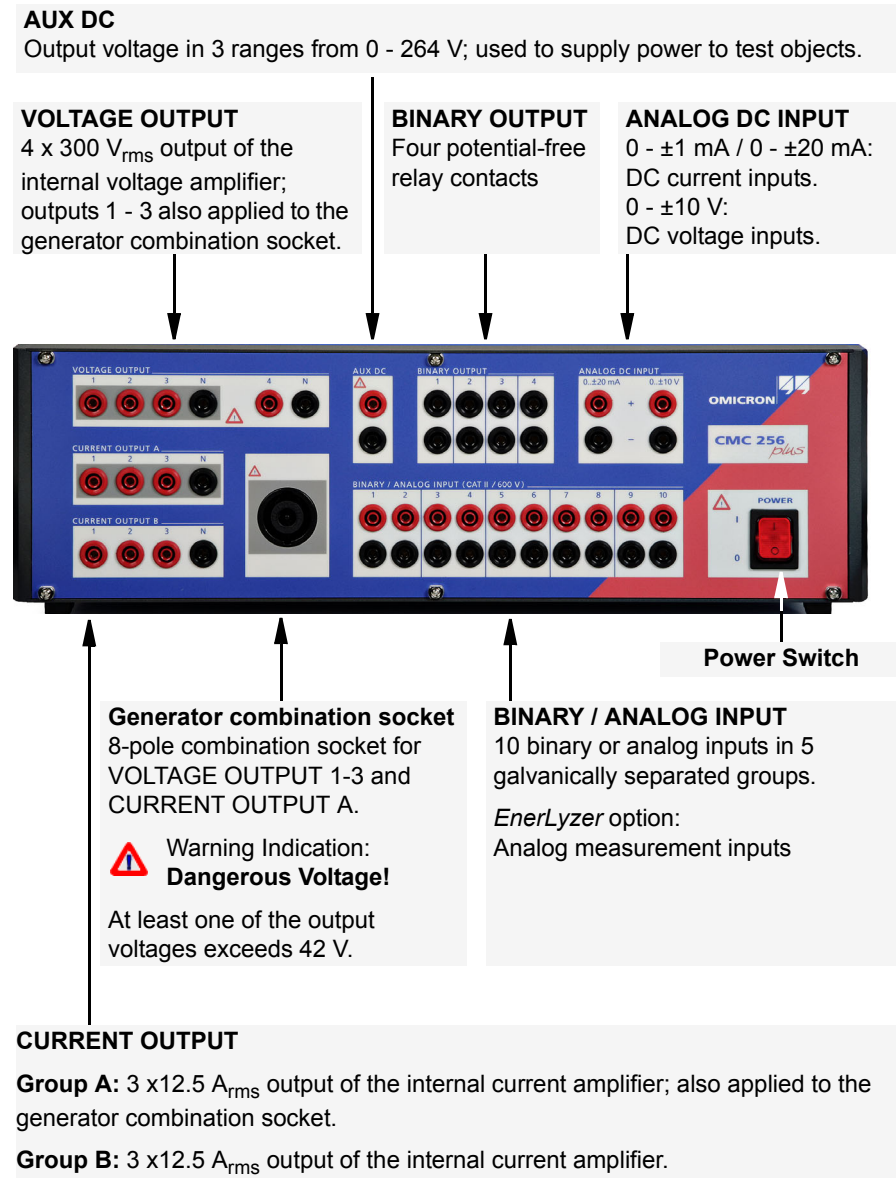
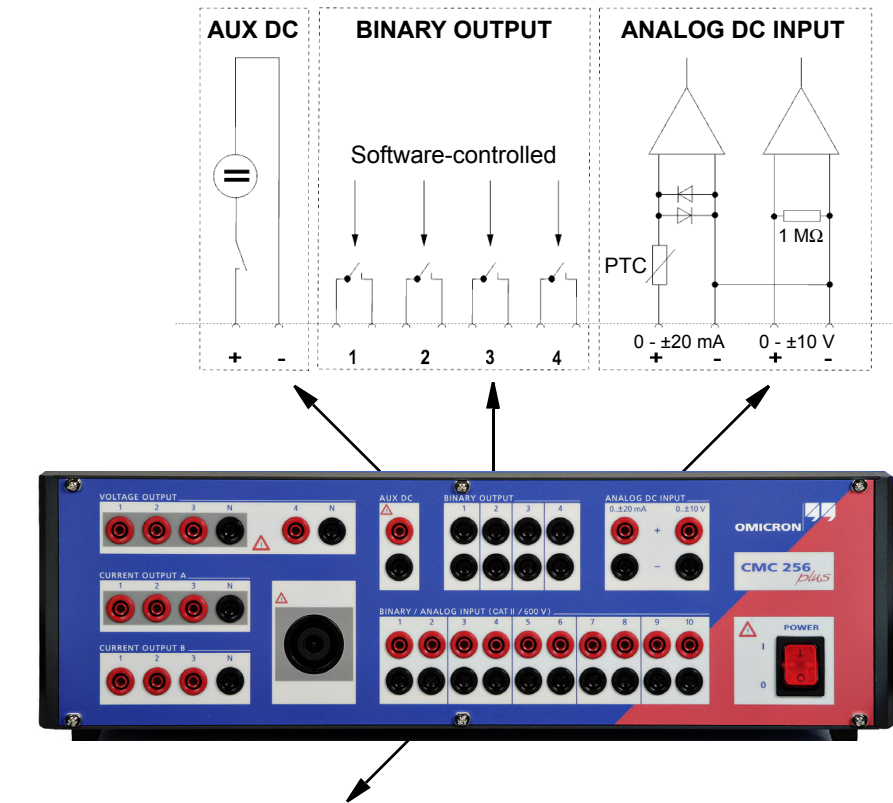
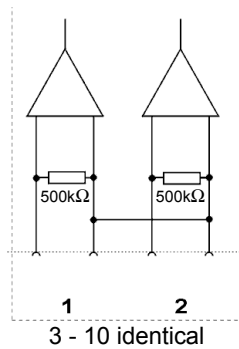


Figure 5-2:  
Simplified diagrams of  
analog and binary inputs  
and outputs



**BINARY/ANALOG INPUT (CAT II / 600 V)**



**Circuit diagram of a binary input  
for potential-free contacts**

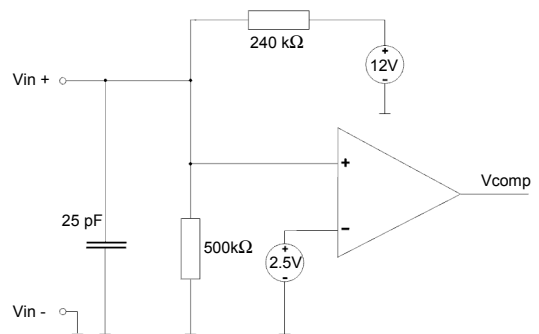
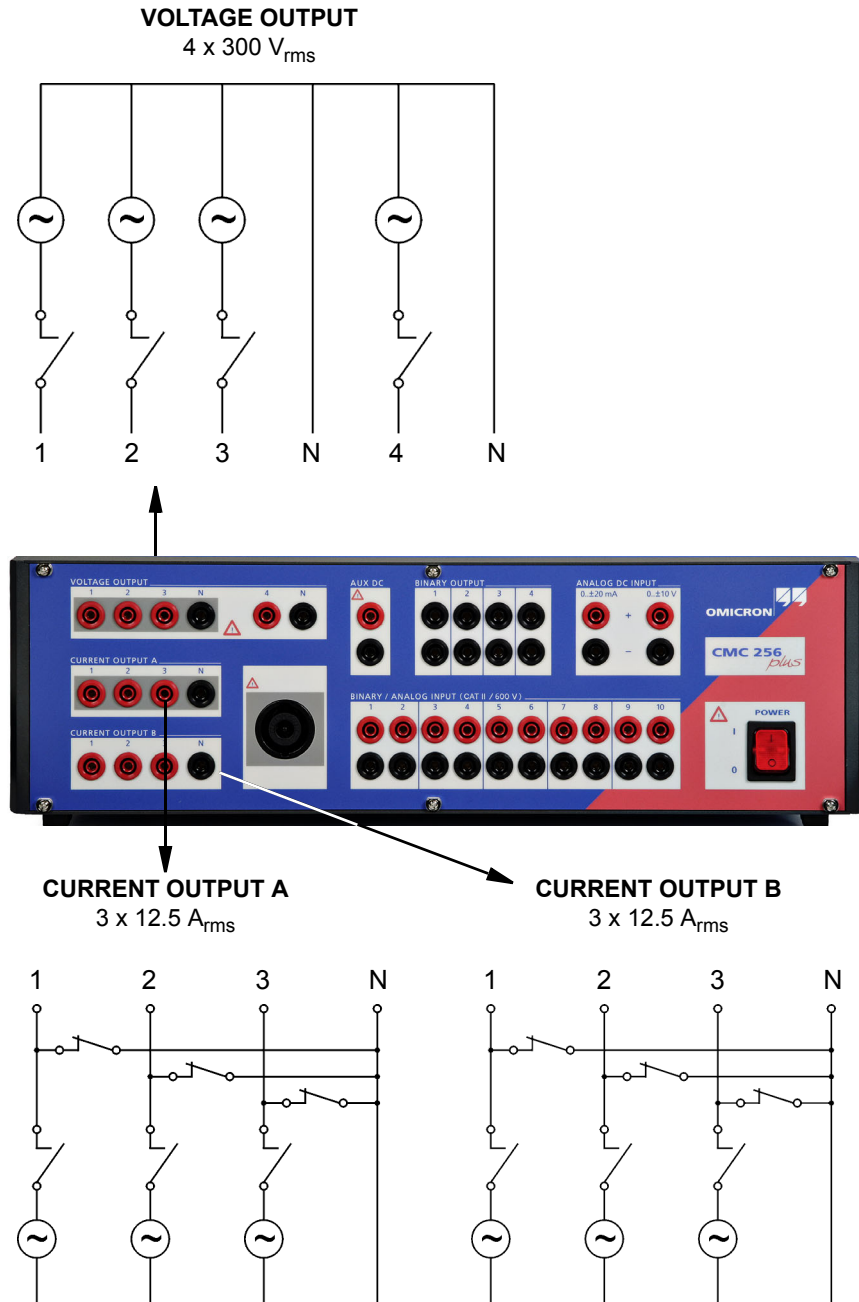


Figure 5-3:  
Simplified diagrams of  
current and voltage  
outputs



In non-operative state, relay contacts (as illustrated in figure 5-3) protect the current amplifier from external power by shortening the outputs to N.

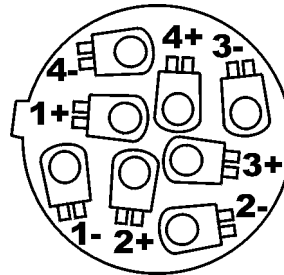
### 5.1.1 Generator Combination Socket for VOLTAGE OUTPUT and CURRENT OUTPUT

The combination socket CURRENT OUTPUT / VOLTAGE OUTPUT simplifies the connection of test objects to the CMC 256. The three voltage outputs (VOLTAGE OUTPUT 1-3) as well as the CURRENT OUTPUT A are wired to the combination socket (refer to table 5-1 on page 33).

Figure 5-4:  
Generator combination  
socket



Front view



View onto the connector from  
the rear cable wiring side

#### WARNING:



The connections on the socket are dangerous when the test set is turned on.

Follow the safety information provided at the beginning of this manual when connecting the generator combination sockets.

If a dangerous voltage (greater than 42 V) is applied to the socket, a warning indicator lights above the socket.

For currents greater than 25 A, the test object (load) should be exclusively connected to the 4 mm/0.16 " banana sockets and not on the generator connection socket.



Table 5-1:  
Pin layout

Pin	Signal
1-	VOLTAGE N
2-	VOLTAGE 3
3-	VOLTAGE 2
4-	VOLTAGE 1
1+	CURRENT A 1
2+	CURRENT A N
3+	CURRENT A 3
4+	CURRENT A 2

**Note:** If using negative sequence phase rotation, swap the connectors VOLTAGE 2 and VOLTAGE 3 as well as CURRENT 2 and CURRENT 3.

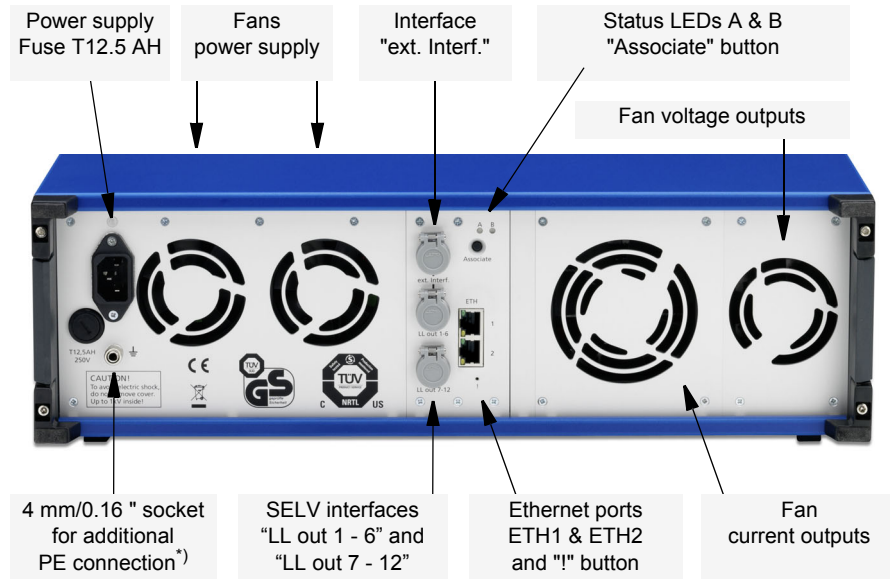
Table 5-2:  
Manufacturer ordering  
information

Description of the generator combination socket	
Description	SPEAKON LINE 8-pole
Article Number	NL8FC
Manufacturer	Neutrik ( <a href="http://www.neutrik.com">www.neutrik.com</a> )

You can order the plug for generator combination socket directly from OMICRON. For the part number refer to section 9.10, "Ordering Information" on page 138.

## 5.2 Connections on the Back Panel

Figure 5-5:  
Rear view of CMC 256



\*) For example to connect to low resistance grounding bars.

The SELV interface LL out 7 - 12 is optional. Please refer to section 5.2.6.3.

For the rear view of CMC 256 with the PAR-1 option (parallel port instead of Ethernet ports), refer to section 6.11.

### 5.2.1 Ethernet Ports ETH1 and ETH2

The two PoE Ethernet (**P**ower **o**ver **E**thernet) ports ETH1 and ETH2 are standard 10/100Base-TX (twisted pair) Ethernet ports. They support auto crossing (auto MDI/MDIX). This means you can use a standard cable or a cross-over Ethernet patch cable.

**Note:** If your Ethernet ports ETH1 and ETH2 look different, i.e., ETH2 is the connector version of Fast Ethernet over optical fiber, refer to chapter 6.5, "Technical Data of the Ethernet Ports" on page 74.

Since the CMC test set can be controlled over a network, any distance between the controlling computer and the test set is possible. This enables direct remote control of the CMC test set, e.g., for end-to-end testing.

The Ethernet ports also provide the basis for the processing of substation protocols according to the IEC 61850 standard. They allow flexible configurations, e.g., for separation of data traffic from different network segments or segregation of substation protocol data and test set control commands.

The green LED indicates a link connection to a PC or a network. The yellow LED indicates active traffic (receiving or transmitting) on the cable.



For detailed technical data about the Ethernet ports, please refer to section 6.5, "Technical Data of the Ethernet Ports" on page 74.

### 5.2.2 ! Button



The ! button enables you to recover from unsuccessful software image downloads or other emergency situations. To start a new software image download, press the ! button with a pointed tool or a paper clip while powering-up the CMC. In that case, the test set will not start as usual but wait for a new software image download.

### 5.2.3 Associate Button



The Associate button has the following functions:

- **Association with controlling computer**

An Ethernet communication port enables you to communicate with any CMC available on the network. This may lead to dangerous situations where a user accidentally connects to a device located on a desk of somebody else, emitting unsafe voltages and endangering the person working there.

To prevent such a situation, a special mechanism is integrated into the CMC test set that allows only "authorized" clients to control the test set. By using the **Associate** button, the test set is registered for use with a specific host computer.

The test set will issue voltages and currents only when it is associated to the client requesting this. The association process can be initiated by the *Test Set Association and Configuration* tool or by the *OMICRON Device Browser*. For more details about this process, refer to the Help of the according tool.

For the association the Ethernet hardware address (MAC) of the controlling computer is remembered. Consequently, if the network interface on the computer has changed, the CMC test set has to be associated whenever the MAC address changes.

- **Reset IP Configuration**

If the **Associate** button is pressed while powering up the CMC test set, the IP configuration of the network interfaces is reset to factory default, which is DHCP/AutoIP for both network interfaces. It may be necessary to reset the IP configuration in this way to recover from settings with conflicting static IP addresses.

#### 5.2.4 Status LED A, B



The status LED A and B are of interest in case of troubleshooting.

**A:** yellow status LED

- A lit yellow LED indicates that the test set is ready to be controlled by a computer. The hardware checks in the test set are finished, and the test set is properly connected to a computer or a network.
- The LED is off when the test set is waiting for an "emergency software image download". This is the case when pressing the ! button while powering-up the CMC test set.

**B:** green LED

If the yellow LED A is off, the green LED B signals the following conditions:

- LED B blinks slowly:  
CMC test set waits for the TFTP download (Trivial File Transfer Protocol) of a software image.
- LED B is lit:  
The TFTP download of the software image is in progress.
- LED B blinks quickly:  
The computer writes (e.g., the software image) to the flash memory of the CMC test set. Do not turn off the CMC test set as long as the writing is in progress.

#### 5.2.5 Ethernet / Network Settings

##### General

The OMICRON *Test Universe* software running on the computer communicates with the CMC test set via a network connection. Therefore it is possible to either have the CMC directly connected to the computer's network plug by a cable or to have the CMC and the controlling computer connected to a computer network.

Both network ports can be used equally, and both network ports have link LEDs (green) and traffic LEDs (yellow flashing) to check the physical connectivity and proper cabling.

## IP Configuration

For the CMC test set to communicate with the controlling computer and the OMICRON *Test Universe* software, TCP/IP is used. The IP parameters are set by either the *Test Set Association and Configuration* tool or the *OMICRON Device Browser*.

The CMC test set can either be set to static IP addresses or use DHCP (**D**ynamic **H**ost **C**onfiguration **P**rotocol) and AutoIP/APIPA (**A**utomatic **P**rivate **I**P **A**ddressing).

Additionally, there is a special DHCP server integrated in the CMC test set to serve IP addresses only for that computer the OMICRON *Test Universe* software is running on. Note that this will only take place when there is no DHCP server in the network. If there is DHCP server in the network, the DHCP feature of the CMC test set remains inactive.

If the IP settings conflict with IP settings of other devices in the network, it is possible to reset the test set to factory defaults (DHCP and AutoIP) by pressing the **Associate** button at the rear of the test set while powering up the test set.

## Security / Firewall Settings

To automatically detect and set the IP configuration of CMC test sets in the network, IP-multicasting is used by the *Test Universe* software. Therefore, a firewall program has to be configured to allow for this communication. For the Microsoft Windows Firewall in Windows XP SP2 (or later) the configuration of the firewall is done automatically during installation of the OMICRON *Test Universe*.

The software component on the computer that automatically detects test sets on the network (OMFind.exe) requires an enabled inbound connection on port 4987 for UDP. For TCP communication, the software component on the computer that controls the test sets (CMEngAI.exe) requires an enabled outbound connection on port 2200.



More information about the Firewall configuration can be found in the FAQ section of the **Get Support** booklet (Technical Support for CMC Test Sets). This manual is available as PDF file on your hard disk after the installation of OMICRON *Test Universe*. Its name is **\_Support Booklet.pdf**.

## Network Troubleshooting



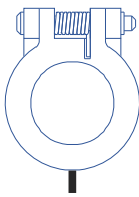
For instructions to help you to incorporate network-capable CMC test sets into a computer network, please refer to the manual **Network-based CMC Test Sets**. This manual is available as PDF file on your hard disk after the installation of OMICRON *Test Universe*. Its name is **Network-based test sets.pdf**.

To view the manuals, start the *Test Universe* Help from the *Start Page* or any test module and navigate to the table of contents entry **User Manuals** (at the beginning of the table of contents). Click **Read Me First**. In this topic you find direct links to both manuals. To open a manual, just click the link.

## 5.2.6 SELV Interfaces

All inputs and outputs to the SELV group (SELV = Safety Extra Low Voltage) reference to a common neutral that is internally connected to the protective earth (GND) of the housing.

### 5.2.6.1 External Interface ("ext. Interf.")



ext. Interf.

The SELV interface connector "ext. Interf." holds four additional transistor **binary outputs** (Bin. out 11 - 14). Unlike regular relay outputs, Bin. out 11 - 14 are bounce-free binary outputs (small signals) and have a minimal reaction time.

In addition, two high frequency **counter inputs** for up to 100 kHz are available for the testing of energy meters.

For more detailed information please refer to the technical data section 6.3.9, "Low-Level Binary Outputs ("ext. Interf.")" on page 64.

### Meter Testing

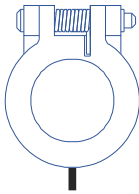
For energy meter test applications, the "ext. Interf." permits easy connectivity. For more information about the connection of scanning heads please refer to sections 9.8.5, "Adapter Cable for Scanning Heads" on page 128 and 9.8.6, "CMLIB B" on page 129.

### Synchronization

Via the "ext. Interf.", the *CMC 256* time base can be GPS- and IRIG-B-synchronized. Depending on the synchronization method of your choice, use either the *CMGPS* synchronization unit or the *CMIRIG-B* interface box.

Both synchronization accessories, the *CMGPS* and the *CMIRIG-B*, are optional and are described in more details in section 9.5, "Time Synchronization Accessories" on page 118.

### 5.2.6.2 LL out 1-6 (Low Level Outputs 1-6)



LL out 1 - 6

The SELV interface connector "LL out 1 - 6" holds two independent generator triples. These six high accuracy analog signal sources can serve to either control an external amplifier or to directly provide small signal outputs.

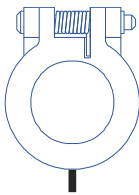
In addition, a serial digital interface is available that transmits control and monitor functions between the *CMC 256* and the external amplifiers. Supported devices are the *CMA 156*, *CMA 56*<sup>1</sup>, *CMS 156*, *CMS 251*<sup>1</sup> and *CMS 252*.

The low level outputs are short-circuit-proof and continually monitored for overload.

Connect the external amplifier to the *CMC 256* low level outputs. Use the connecting cable that was supplied with the amplifier.

For more detailed information please refer to the technical data section 6.3.8, "Low Level Outputs "LL out" for External Amplifiers" on page 62.

### 5.2.6.3 LL out 7-12 (Low Level Outputs 7-12) - Option "LLO-2"



LL out 7 - 12

The SELV interface connector "LL out 7 - 12" is an option available for the *CMC 256* test set.

The outputs 7-12 extend the low level outputs 1-6 by two more independent generator triples. Outputs 7-12 are technically identical to outputs 1-6 as described above.

For more detailed information please refer to the technical data section 6.11, "Option LLO-2 (Low Level Outputs)" on page 90.

#### Overload Warning Flagged in the Software

When a low level output is overloaded, a corresponding warning message appears on the user interface of the *OMICRON Test Universe* software.

<sup>1</sup> This product is not available anymore.





## 6 TECHNICAL DATA

### Guaranteed Values:

- General:  
The values are valid for the period of one year after factory calibration, within  $23\text{ °C} \pm 5\text{ °C}$  at nominal value and after a warm-up time greater than 25 min.
- Guaranteed values from the generator outputs:  
The values are valid in the frequency range from 10 to 100 Hz unless specified otherwise. Given maximum phase errors are related to the voltage amplifier outputs.
- Accuracy data for analog outputs are valid in the frequency range from 0 to 100 Hz unless specified otherwise.
- The given input/output accuracy values relate to the range limit value (% of range limit value).

### 6.1 Main Power Supply

Table 6-1:  
Power supply data

Main Power Supply	
Connection	Connector according to IEC 60320
Voltage, single phase nominal voltage operational range	100 - 240 V <sub>AC</sub> 85 ... 264 V <sub>AC</sub>
Power fuse	T 12.5 AH 250 V (5 x 20 mm) "Schurter", order number 0001.2515
Nominal current <sup>1</sup>	at < 170 V: 12 A max. at > 170 V: 10 A max.
Frequency nominal frequency operational range	50/60 Hz 45 ... 65 Hz
Overvoltage category	II

<sup>1</sup> Refer to section 6.3.7, "Operational Limits in Conjunction with a Weak Mains Supply Voltage" on page 61.

## 6.2 Insulation Coordination

Table 6-2:  
Insulation coordination

Insulation Coordination	
Overvoltage category	II
Pollution degree	2 (except for Binary Inputs)
Insulation of function groups on front panel to ground (GND) <sup>1</sup>	<ul style="list-style-type: none"> <li>- Basic insulation with maximum voltage of 600 V<sub>rms</sub> to ground</li> <li>- Clearance: &gt; 3 mm (0.12 ")</li> <li>- Creepage: &gt; 6 mm (0.24 ")</li> <li>- Test voltage: 2200 V<sub>rms</sub></li> </ul>
Insulation of functional groups on front panel from each other	<ul style="list-style-type: none"> <li>- Working insulation</li> <li>- Clearance: &gt; 1 mm (0.04 ")</li> <li>- Creepage: &gt; 1 mm (0.04 ")</li> <li>- Test voltage: 1500 VDC</li> </ul>
Measurement category (BINARY / ANALOG INPUTS)	<ul style="list-style-type: none"> <li>- CAT II / 600 V<sub>rms</sub></li> <li>- CAT III / 300 V<sub>rms</sub></li> <li>- CAT IV / 150 V<sub>rms</sub></li> </ul>

<sup>1</sup> Functional groups on CMC 256 front panel:  
VOLTAGE OUTPUT, CURRENT OUTPUT (A, B), AUX DC, BINARY OUTPUT,  
BINARY / ANALOG INPUT, ANALOG DC INPUT

## 6.3 Outputs

For block diagrams of the available generator outputs, please refer to section 4.1, "Block Diagram" on page 20.

Table 6-3:  
Analog current, voltage,  
and LL outputs.

<b>General Generator Outputs Data (Analog current and voltage outputs, and "LL out" outputs)</b>		
Frequency ranges <sup>1</sup> sinusoidal signals <sup>2</sup> transient signals	10 ... 3000 Hz 0 (DC) ... 3.1 kHz	
Frequency resolution	< 5 µHz	
Frequency accuracy	± 0.5 ppm	
Frequency drift	± 1 ppm	
Bandwidth (-3 dB)	3.1 kHz	
Phase range φ	- 360 ° to + 360 °	
Phase resolution	0.001 °	
Phase error <sup>3</sup>	Typical 0.005 °	Guaranteed < 0.02 °
Synchronized operation	Generator outputs could be synchronized to a reference input signal on binary/analog input 10 (range: 40 ... 70 Hz).	
Temperature drift	0.0025 %/°C	

<sup>1</sup> If you purchased the option **FL-6**, the maximum output frequency is constrained to **599 Hz**.

<sup>2</sup> Signals above 1 kHz are only supported in selected software modules.

<sup>3</sup> Valid for sinusoidal signals at 50/60 Hz.

All voltages and current generators can independently be configured with respect to amplitude, phase angle, and frequency.

All outputs are monitored. Overload conditions result in a message displayed on the PC.

### 6.3.1 Extended Frequency Range

In selected *Test Universe* modules (e.g., *Harmonics* and *PQ Signal Generator*) the *CMC 256plus* supports a mode for generating stationary signals up to 3 kHz. This mode corrects the phase and gain errors of the output filter. The 3 dB bandwidth of this filter limits the amplitude at 3 kHz to about 70 % of the maximum range value. The application of the extended frequency range is the generation of harmonics and interharmonics.

Table 6-4:  
Extended frequency range  
(1 - 3 kHz)

Extended Frequency Range (1 - 3 kHz)		
	Typical	Guaranteed
Low Level Outputs <sup>1</sup>		
Phase error	< 0.25 °	< 1 °
Amplitude error	< 0.25 %	< 1 %
Voltage Amplifier		
Phase error	< 0.25 °	< 1 °
Amplitude error	< 0.25 %	< 1 %
Current Amplifier <sup>2</sup>		
Phase error	not specified	
Amplitude error	not specified	

<sup>1</sup> No extended frequency range support for external amplifiers.

<sup>2</sup> Amplifier is calibrated with low resistance burden. The error is highly burden dependent and therefore not quantified.

### 6.3.2 CURRENT OUTPUT A and B

Table 6-5:  
Outputs of current groups  
A and B

**Footnotes:**

1. Data for three-phase systems are valid for symmetric conditions (0°, 120°, 240°).
2. Three-phase parallel switched.
3. Single-phase mode (in phase opposition):  
2 currents in series.
- 4 rd. = reading;  
rg. = range, whereat  
*n* % of rg. means: *n* % of upper range value.
5. Values at 50/60 Hz,  
20 kHz measurement bandwidth, nominal value, and nominal load.
6. For currents > 25 A,  
connect test object only to the 4 mm/0.16" banana connections and not to the generator combination socket.

2 x 3 Current Outputs <sup>1</sup> (Groups A and B)		
Output currents		
3-phase AC (L-N)	3 x 0 ... 12.5 A	
1-phase AC (L-N) <sup>2</sup>	1 x 0 ... 37.5 A	
DC (L-N) <sup>2</sup>	1 x 0 ... ±17.5 A	
DC (L-N)	1 x 0 ... ±12.5 A	
Power (range II)	Typical	Guaranteed
3-phase AC (L-N)	3 x 80 VA at 8.5 A	3 x 70 VA at 7.5 A
1-phase AC (L-N) <sup>2</sup>	1 x 240 VA at 25.5 A	1 x 210 VA at 22.5 A
1-phase AC (L-L) <sup>3</sup>	1 x 160 VA at 8.5 A	1 x 140 VA at 7.5 A
DC (L-N) <sup>2</sup>	1 x 240 W at ±17.5 A	1 x 235 W at ±17.5 A
DC (L-N)	1 x 100 W at ±12.5 A	1 x 90 W at ±12.5 A
Power (range I)	3 x 12.5 VA at 1.25 A	
3-phase AC (L-N)		
Accuracy (range II)	Typical	Guaranteed
$R_{load} \leq 0.5 \Omega$	Error < 0.015 % rd. <sup>4</sup> + 0.005% of rg.	Error < 0.04 % of rd. + 0.01% of rg.
$R_{load} > 0.5 \Omega$	Error < 0.02 % of rg.	Error < 0.05 % of rg.
Accuracy (range I)	Error < 0.04 % of rd. + 0.01 % of rg.	
$R_{load} \leq 1 \Omega$	Error < 0.015 % of rd. + 0.005 % of rg.	Error < 0.04 % of rd. + 0.01 % of rg.
Harmonic distortion (THD+N) <sup>5</sup>	0.025 %	< 0.07 %
DC offset current		
range I	< 30 µA	< 300 µA
range II	< 300 µA	< 3 mA
Current ranges	Range I: 0 ... 1.25 A Range II: 0 ... 12.5 A	
Resolution	< 50 µA (1.25 A range) < 500 µA (12.5 A range)	
Short-circuit protection	Unlimited to N	
Open-circuit protection	Open outputs (open-circuit) permitted	
Connection	4 mm/0.16" banana connectors, amplifier connection socket <sup>6</sup> (CURRENT OUTPUT A only)	
Insulation	Reinforced insulation of power supply and all SELV interfaces	

### 6.3.2.1 Typical Duty Cycles for Different Loads and Output Configurations

#### Terms and definitions

"Continuous operation" or "100 % duty cycle" is defined as a CMC test set being able to provide a specified current for at least 30 minutes without shutting down due to overtemperature.

A duty cycle of 75 %, for example, means, the CMC test set provides the specified current 75 % of the time, and needs the remaining 25 % of the time to cool off (e.g.: 30 s on and 10 s off).

Preconditions that apply to duty cycles:

- On the **Output Configuration Details** dialog of the *Test Universe Hardware Configuration*, the compliance voltage is set to 100 % (15 V), and the fan mode is set to maximum power.
- The duty cycle values denoted below apply to output frequencies of 50 Hz thru 60 Hz and to sinus signals. For other frequencies or output wave forms the results may vary.
- The duty cycle values denoted below apply to resistive loads only, not to inductive or capacitive loads.
- For 3- and 6-phase operation, the phase angles between the currents are 0 °, 120 °, 240 °.

#### Measuring method

Every tests starts with a heat sink temperature of ambient temperature + 15°C. Then the CMC test set starts to provide the specified current.

If within 30 minutes no shutdown due to overtemperature occurred, the measurement for this particular current is finished, and the duty cycle for this current value equals 100 %.

In case an overtemperature shutdown occurred, the time between the actual shutdown and the moment the CMC test set can be restarted is defined as "cooling time" ( $t_{cooling}$ ).

The time between the restart of the CMC test set and its next shutdown due to overtemperature is defined as "on time" ( $t_{on}$ ).

Using these two time definitions, the duty cycle calculates as follows:

$$\text{duty cycle} = \frac{t_{on}}{t_{on} + t_{cooling}}$$

With regard to the following duty cycle graphs please note that when selecting a current of 12 A, continuous operation is possible at much smaller load resistance than, for example, with a current of 10 A. That is because the *CMC 256* linearly reduces the compliance voltage from 15 V to 10.5 V for currents in the range of 8 A to 12.5 A per phase.

Note: In order to get the approximate duty cycle values for 3 x 25 A and 1 x 75A configurations, please refer to the 6 x 12.5 A configuration graphs, and divide the load values at the X-Axis by 3 or 6.

Figure 6-1:  
Typical possible duty cycle  
at  $R_{Load} = 3 \times 0 \Omega$

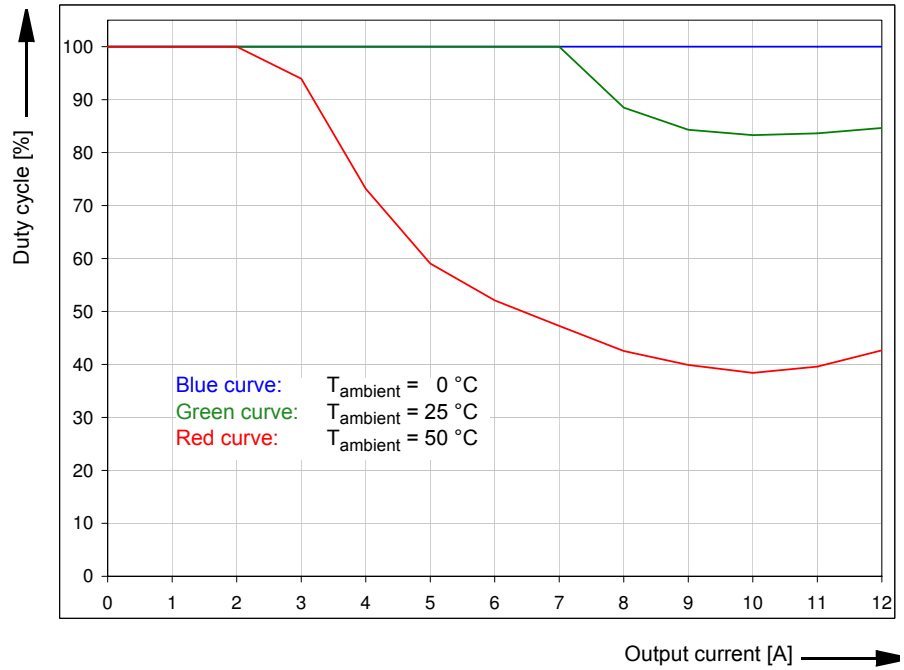


Figure 6-2:  
Typical possible duty cycle  
at  $R_{Load} = 6 \times 0 \Omega$

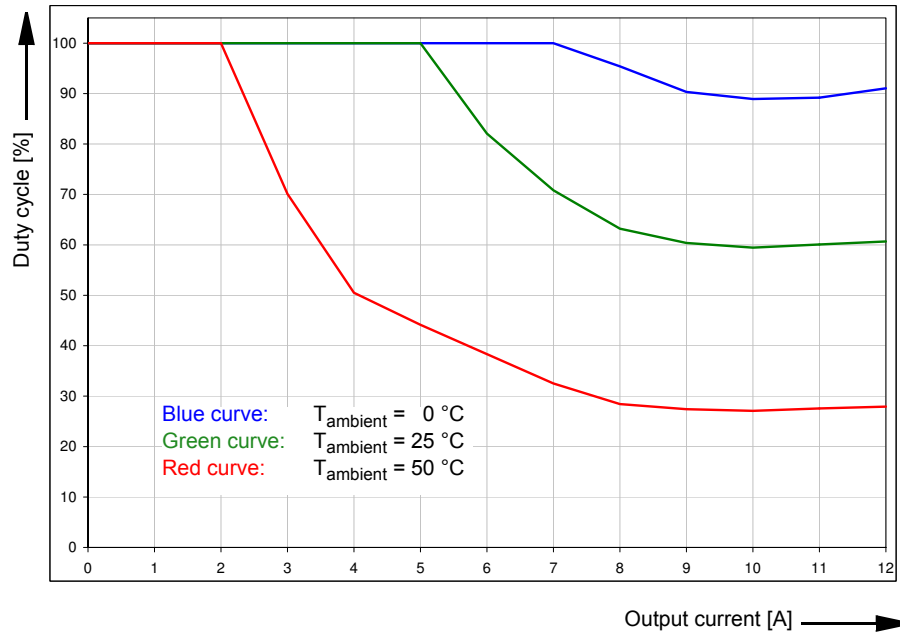




Figure 6-3:  
Typical duty cycles in a  
1 x 12.5 A configuration at  
 $T_{\text{ambient}} = 25\text{ }^{\circ}\text{C}$

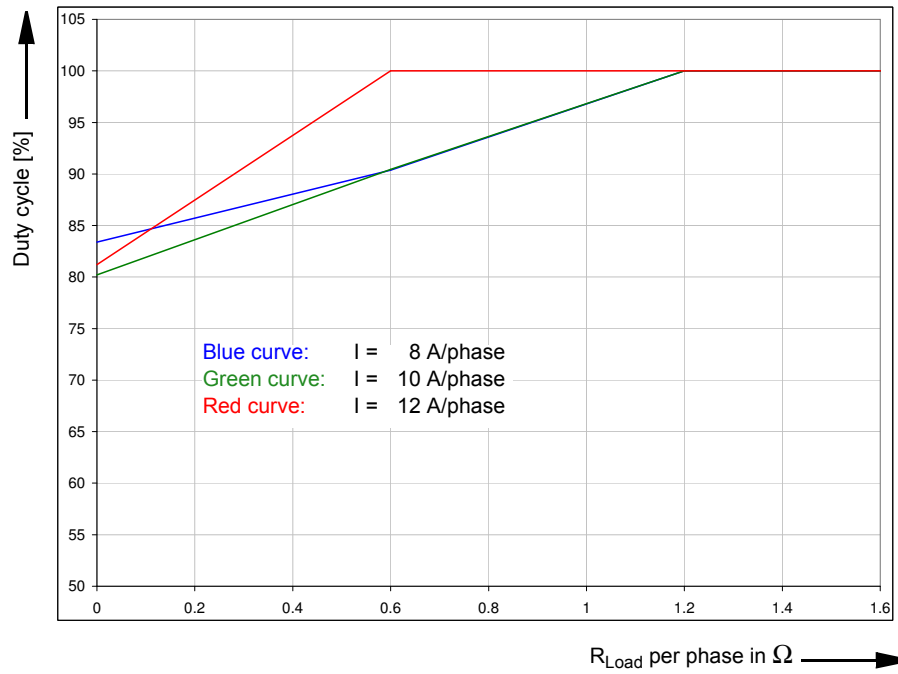


Figure 6-4:  
Typical duty cycles in a  
1 x 12.5 A configuration at  
 $T_{\text{ambient}} = 50\text{ }^{\circ}\text{C}$

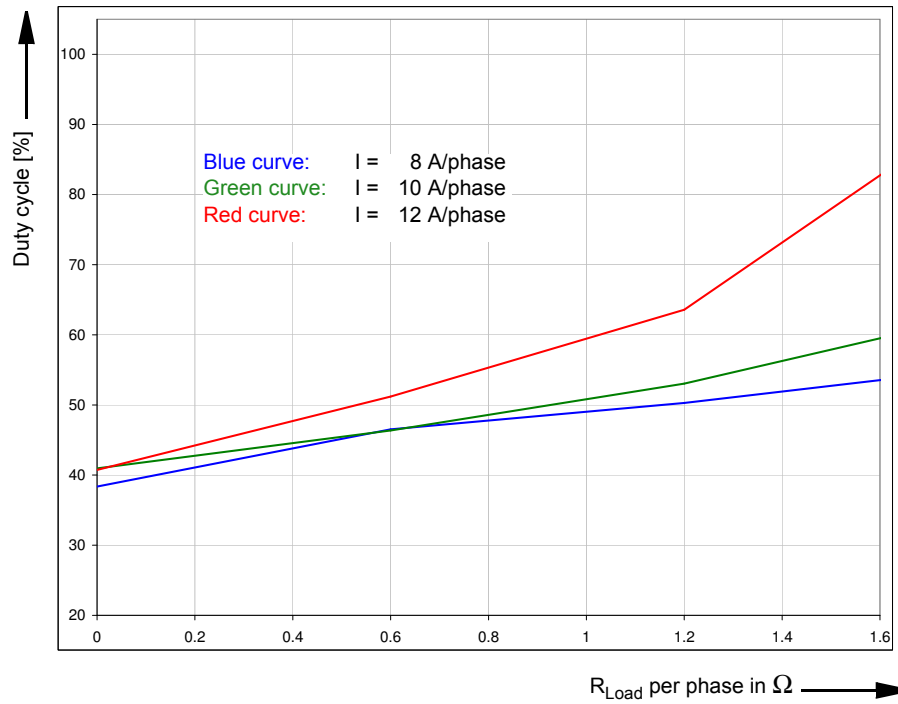


Figure 6-5:  
Typical duty cycles in a  
3 x 12.5 A configuration at  
 $T_{\text{ambient}} = 25\text{ }^{\circ}\text{C}$

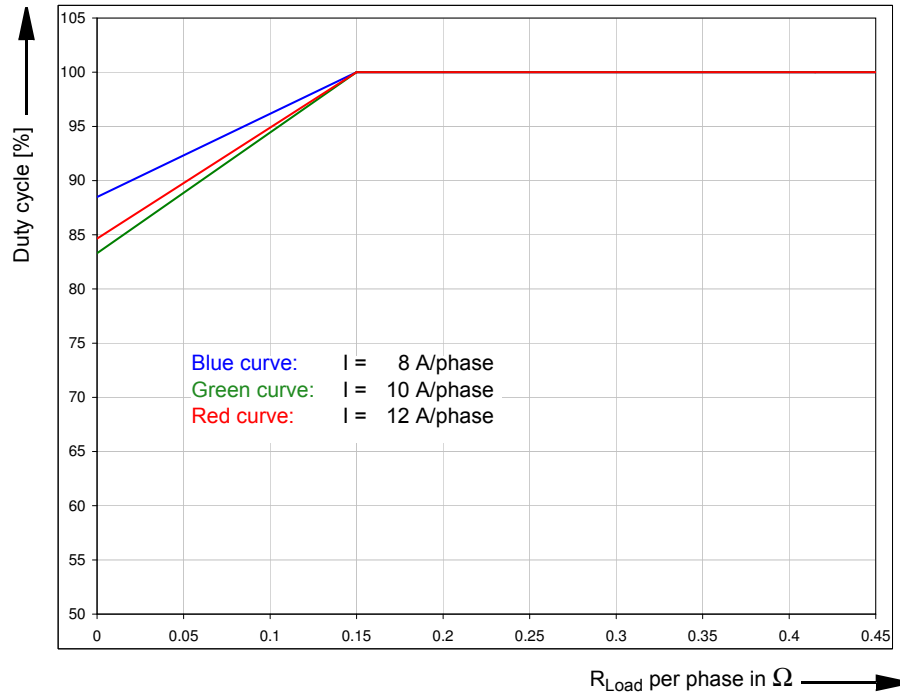


Figure 6-6:  
Typical duty cycles in a  
3 x 12.5 A configuration at  
 $T_{\text{ambient}} = 50\text{ }^{\circ}\text{C}$

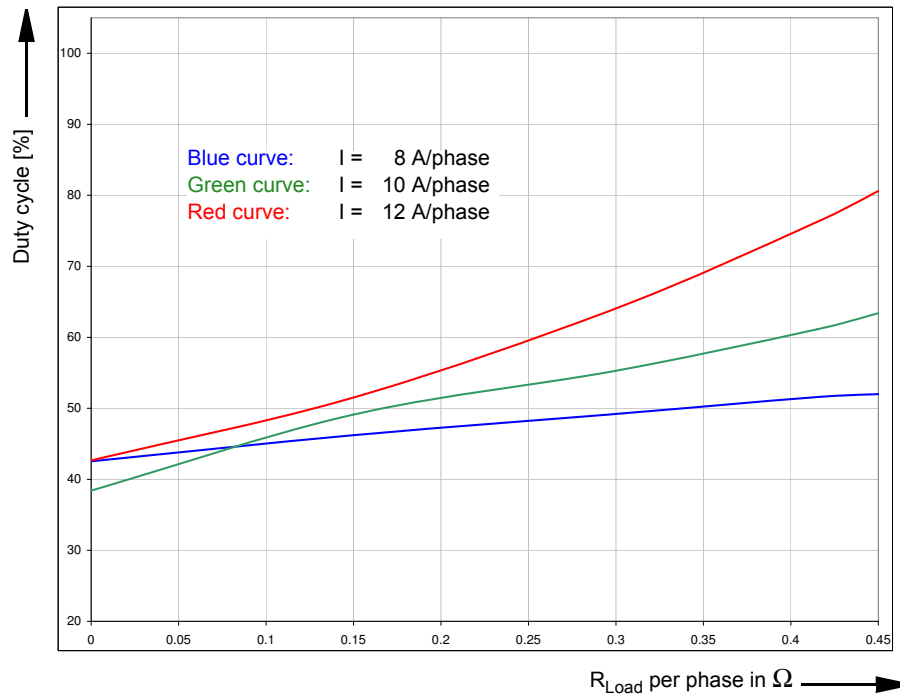


Figure 6-7:  
 Typical duty cycles in a  
 6 x 12.5 A configuration at  
 $T_{\text{ambient}} = 25\text{ }^{\circ}\text{C}$

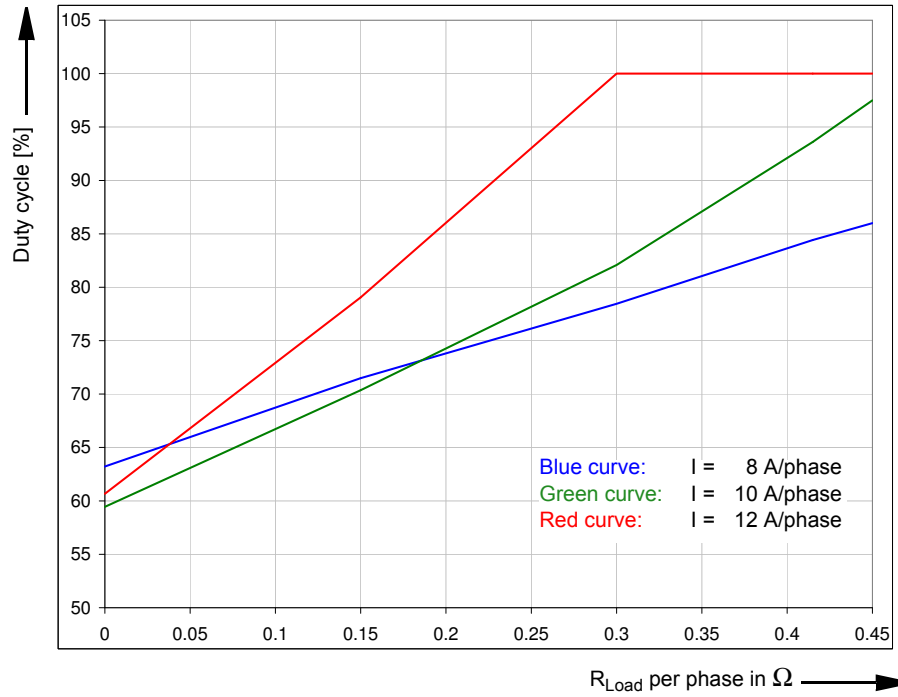
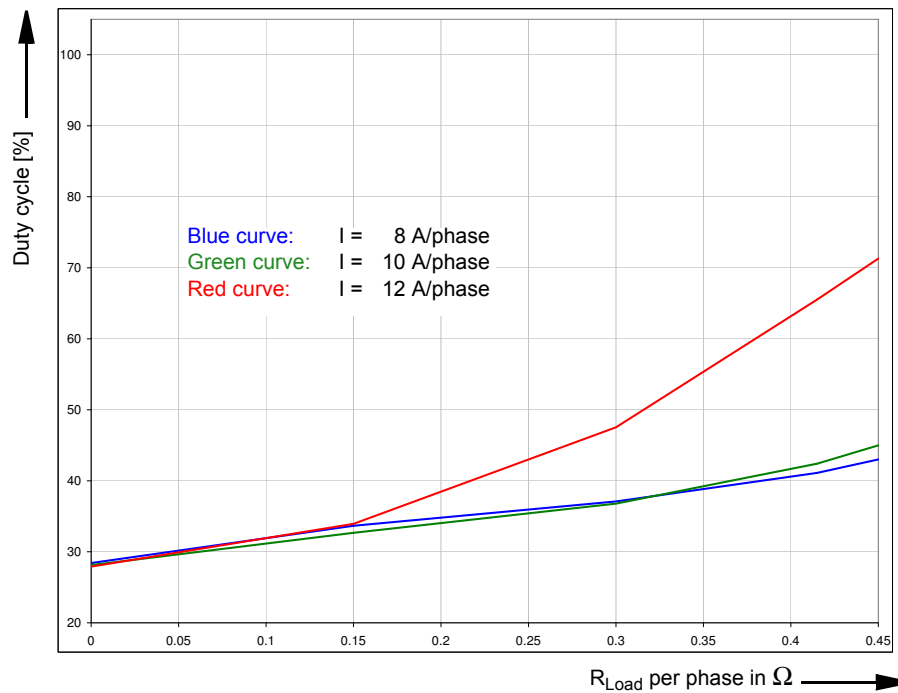


Figure 6-8:  
 Typical duty cycles in a  
 6 x 12.5 A configuration at  
 $T_{\text{ambient}} = 50\text{ }^{\circ}\text{C}$



**Typical first shutdown, cooling times and on times at an ambient temperatures of 25 °C (see also "Measuring method" on page 46):**

$t_1$ : Time until a "cold" CMC test set shuts down.

$t_{on}$ : The time between the restart of the CMC test set and its next shutdown due to overtemperature.

1 x 12.5 A, $R_{Load} = 1 \times 0 \Omega$				
I [A]	$t_1$ [min]	$t_{on}$ [s]	$t_{cool}$ [s]	duty cycle [%]
0...6	> 30	> 1800	-	100
7	9.4	222	17	93
8	5.1	83	17	83
9	4.4	68	17	80
10	4.2	66	17	80
11	4.2	65	17	79
12	4.5	70	17	80

1 x 12.5 A, $R_{Load} = 1 \times 0.6 \Omega$				
I [A]	$t_1$ [min]	$t_{on}$ [s]	$t_{cool}$ [s]	duty cycle [%]
0...7	> 30	> 1800	-	100
8	7.6	162	17	90
9	6.8	120	17	88
10	8.3	161	17	90
11	12.9	380	17	96
12	> 30	> 1800	-	100

3 x 12.5 A, $R_{Load} = 3 \times 0 \Omega$				
I [A]	$t_1$ [min]	$t_{on}$ [s]	$t_{cool}$ [s]	duty cycle [%]
0...7	> 30	> 1800	-	100
8	5.9	124	17	88
9	4.6	88	17	84
10	4.3	82	17	83
11	4.3	82	17	83
12	4.6	89	14	84

3 x 12.5 A, $R_{Load} = 3 \times 0.15 \Omega$				
I [A]	$t_1$ [min]	$t_{on}$ [s]	$t_{cool}$ [s]	duty cycle [%]
0...8	> 30	> 1800	-	100
9	13.9	438	17	96
10	> 30	> 1800	-	100
11	> 30	> 1800	-	100
12	> 30	> 1800	-	100

6 x 12.5 A, $R_{Load} = 6 \times 0 \Omega$				
I [A]	$t_1$ [min]	$t_{on}$ [s]	$t_{cool}$ [s]	duty cycle [%]
0...5	> 30	> 1800	-	100
6	5.3	100	23	81
7	3.6	54	23	70
8	2.8	39	23	63
9	2.5	34	23	60
10	2.4	33	23	59
11	2.4	33	23	59
12	2.5	35	23	60

6 x 12.5 A, $R_{Load} = 6 \times 0.15 \Omega$				
I [A]	$t_1$ [min]	$t_{on}$ [s]	$t_{cool}$ [s]	duty cycle [%]
0...5	> 30	> 1800	-	100
6	8.0	200	23	90
7	4.7	86	23	79
8	3.5	56	23	71
9	3.3	50	23	68
10	3.4	53	23	70
11	3.8	62	23	73
12	4.7	84	23	79

<b>6 x 12.5 A, R<sub>Load</sub> = 6 x 0.3 Ω</b>				
I [A]	t <sub>1</sub> [min]	t <sub>on</sub> [s]	t <sub>cool</sub> [s]	duty cycle [%]
0...6	> 30	> 1800	-	100
7	6.3	139	23	86
8	4.6	81	23	78
9	4.4	77	23	77
10	5.3	101	23	81
11	7.9	197	23	90
12	> 30	> 1800	-	100

<b>6 x 12.5 A, R<sub>Load</sub> = 6 x 0.415 Ω</b>				
I [A]	t <sub>1</sub> [min]	t <sub>on</sub> [s]	t <sub>cool</sub> [s]	duty cycle [%]
0...6	> 30	> 1800	-	100
7	8.9	230	23	91
8	5.9	121	23	84
9	6.3	130	23	85
10	11.3	326	23	93
11	> 30	> 1800	-	100
12	> 30	> 1800	-	100

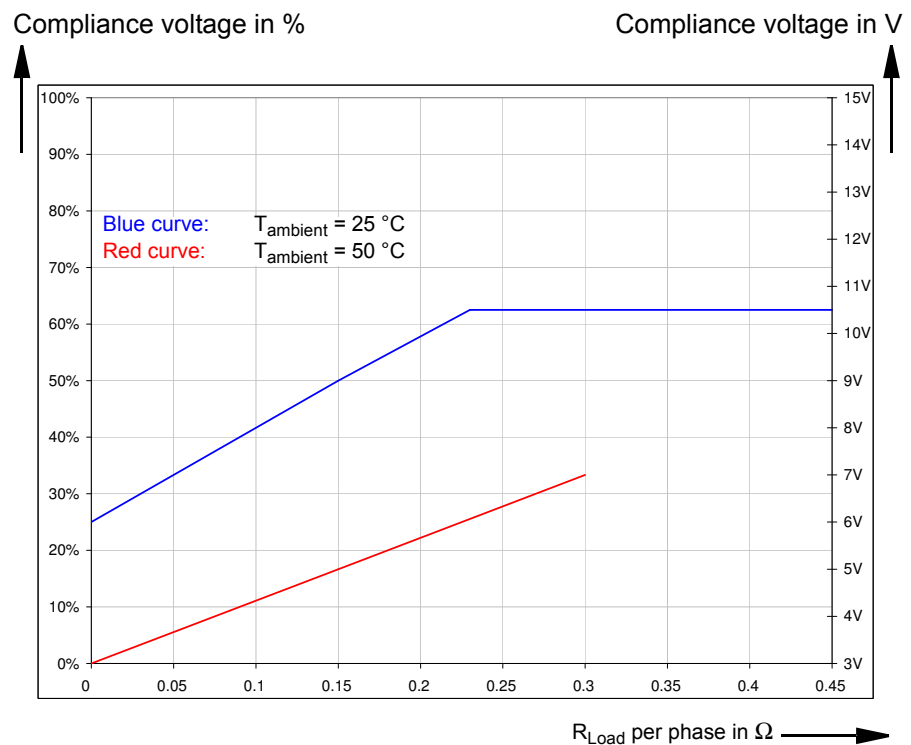
### 6.3.2.2 Ensuring continuous operation

In order to ensure continuous operation, the compliance voltage in the *Test Universe* software can be decreased. Small compliance voltages result in less power dissipation inside the current amplifier, which, however, holds the disadvantage that the current amplifier cannot drive high burdens at high currents. In that case the current amplifier would report an overload.

Figure 6-9 shows the typical possible compliance voltage that ensures continuous operation in a 6 x 12.5 A configuration with the maximum output current of 12.5 A per phase. Since other configurations produce less internal heat dissipation, this diagram can also be used as indicator for these other configurations.

#### Typically allowed compliance voltage to ensure continuous operation

Figure 6-9:  
Typically allowed  
compliance voltage to  
ensure continuous  
operation



At a temperature of 50 °C, the compliance voltage cannot be reduced far enough to ensure continuous operation for loads with a resistance above 0.3 Ω per phase.

### 6.3.3 Parallel Switching of CURRENT OUTPUT A and B

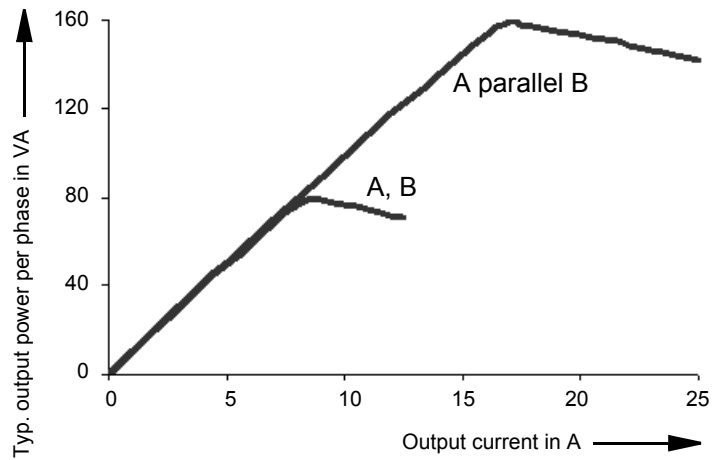
Table 6-6:  
Parallel switched current  
outputs groups A and B

**Footnotes:**

1. Data for three-phase systems are valid for symmetric conditions (0°, 120°, 240°). Also refer to section 6.3.7.
2. Three-phase parallel switched. For a connection diagram refer to section 7.3.
- 3 rd. = reading;  
rg. = range, whereat  $n\%$  of rg. means:  $n\%$  of upper range value.
4. Values at 50/60 Hz, 20 kHz measurement bandwidth, nominal value, and nominal load.
5. For currents > 25 A, connect test object only to the 4 mm/0.16" banana connections and not to the generator combination socket.

Parallel Switched Current Outputs <sup>1</sup> (Groups A and B)		
Output currents		
3-phase AC (L-N)	3 x 0 ... 25 A	
1-phase AC (L-N) <sup>2</sup>	1 x 0 ... 75 A	
DC (L-N) <sup>2</sup>	1 x 0 ... ±35 A	
DC (L-N)	1 x 0 ... ±25 A	
Power (range II)	Typical	Guaranteed
3-phase AC (L-N)	3 x 160 VA at 17 A	3 x 140 VA at 15 A
1-phase AC (L-N) <sup>2</sup>	1 x 480 VA at 51 A	1 x 420 VA at 45 A
1-phase AC (L-L)	1 x 320 VA at 8.5 A	1 x 280 VA at 15 A
DC (L-N) <sup>2</sup>	1 x 480 W at ±35 A	1 x 470 W at ± 35 A
DC (L-N)	1 x 200 W at ±25 A	1 x 180 W at ± 25 A
Power (range I)		
3-phase AC (L-N)		3 x 25 VA at 2.5 A
Accuracy (range II)		
$R_{load} \leq 0.5 \Omega$	Error < 0.015 % of rd. <sup>3</sup> + 0.005 % of rg.	Error < 0.04 % of rd. + 0.01 % of rg.
$R_{load} > 0.5 \Omega$	Error < 0.02 % of rg.	Error < 0.05 % of rg.
Accuracy (range I)		
$R_{load} \leq 1 \Omega$	Error < 0.015 % of rd. + 0.005 % of rg.	Error < 0.04 % of rd. + 0.01 % of rg.
Harmonic distortion (THD+N) <sup>4</sup>	0.025 %	< 0.07 %
DC offset current		
range I	< 60 µA	< 600 µA
range II	< 600 µA	< 6 mA
Current ranges	Range I: 0 ... 2.5 A Range II: 0 ... 25 A	
Resolution	< 100 µA (in range I) < 1 mA (in range II)	
Connection	4 mm/0.16" banana connectors, amplifier connection socket <sup>5</sup>	

Figure 6-10:  
Typical output power  
per phase of a group  
and with parallel switching  
(A || B) of both groups



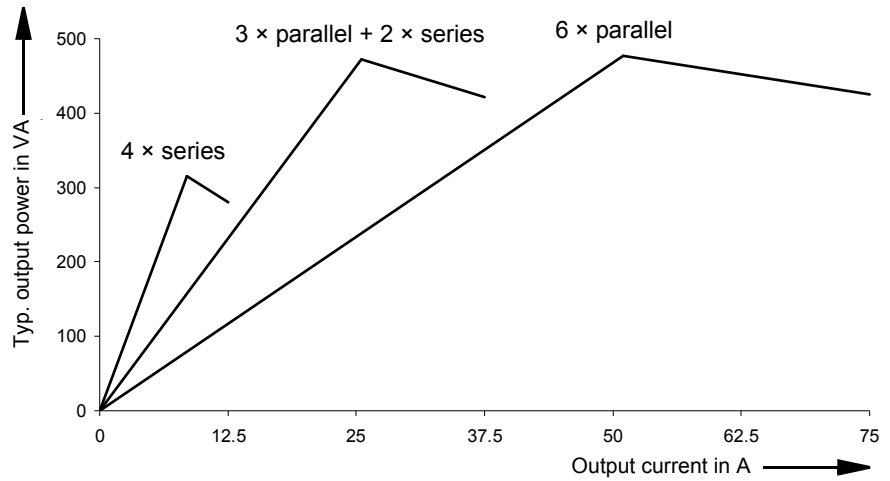
### 6.3.4 Single-phase Operation for Output Currents

Table 6-7:  
Single-phase operation  
of the CMC 256

Single-Phase Operation	
Output currents	
4 x series	1 x 0 ... 12.5 A, refer to section 7.1.
3 x parallel + 2 x series	1 x 0 ... 37.5 A, refer to section 7.2.
6 x parallel	1 x 0 ... 75 A, refer to section 7.3.
Typical power output	
4 x series	1 x 320 VA at 8.5 A
3 x parallel + 2 x series	1 x 480 VA at 25.5 A
6 x parallel	1 x 480 VA at 51 A

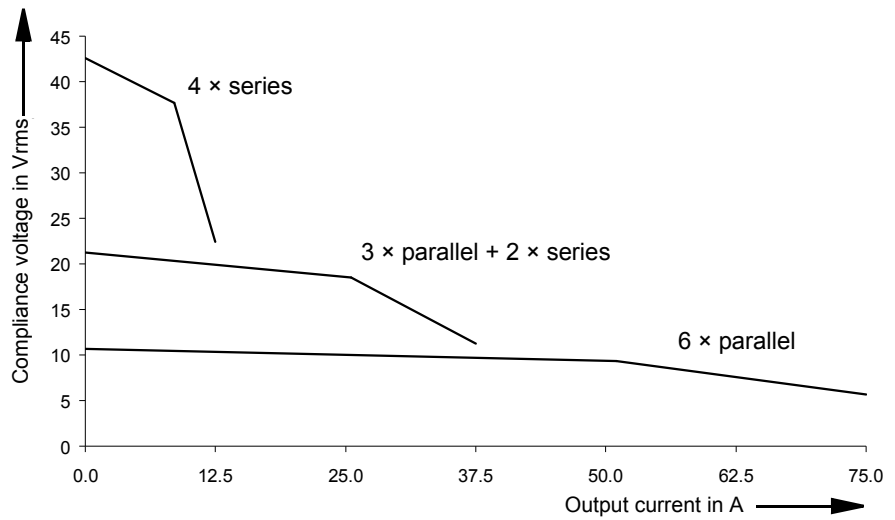


Figure 6-11:  
Typical output power  
curves (50/60Hz)



For additional information refer to section 7, "Increasing the Output Power" on page 99.

Figure 6-12:  
Typical compliance voltage  
(50/60 Hz)



### 6.3.5 Voltage Outputs

Table 6-8:  
CMC 256 voltage outputs

**Footnotes:**

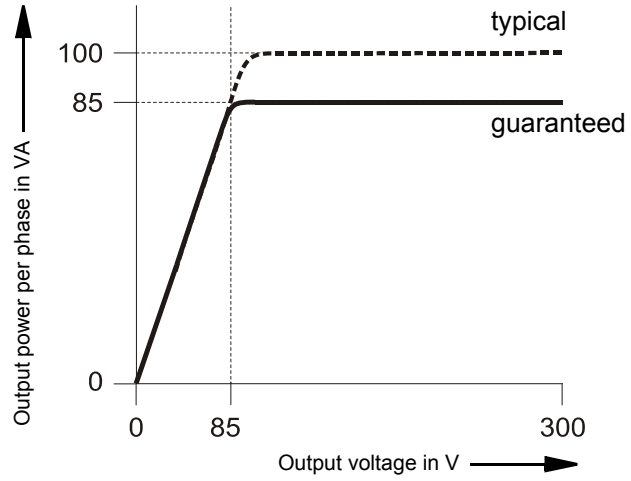
- 1.a)  $V_{L4}$  (t) automatically calculated:  
 $V_{L4} = (V_{L1} + V_{L2} + V_{L3}) * C$   
 C: configurable constant from -4 to +4.  
 b)  $V_{L4}$  can be configured by software in frequency, phase, and amplitude.
2. Guaranteed data for ohmic loads, (PF=1). Refer to the accompanying figure of the output power curves. Refer to section 6.3.7, "Operational Limits in Conjunction with a Weak Mains Supply Voltage" on page 61.
- 3 Data for three-phase systems are valid for symmetric conditions (0°, 120°, 240°).
- 4.Data for four-phase systems are valid for symmetric conditions (0°, 90°, 180°, 270°).
- 5 rd. = reading;  
 rg. = range, whereat  $n\%$  of rg. means:  $n\%$  of upper range value.
6. Values at 50/60 Hz, 20 kHz measurement bandwidth, nominal value, and nominal load.
7. If you purchased the option **FL-6**, the maximum output frequency is constrained to **599 Hz**.

4 Voltage Outputs		
Output voltages		
4-phase AC (L-N) <sup>1</sup>	4 x 0 ... 300 V	
1-phase AC (L-L)	1 x 0 ... 600 V	
DC (L-N)	4 x 0 ... ± 300 V	
Output power <sup>2</sup>	Typical	Guaranteed
3-phase AC <sup>3</sup>	3 x 100 VA at 100 ... 300 V	3 x 85 VA at 85 ... 300 V
4-phase AC <sup>4</sup>	4 x 75 VA at 100 ... 300 V	4 x 50 VA at 85 ... 300 V
1-phase AC (L-N)	1 x 200 VA at 100 ... 300 V	1 x 150 VA at 75 ... 300 V
1-phase AC (L-L)	1 x 275 VA at 200 ... 600 V	1 x 250 VA at 200 ... 600 V
DC (L-N)	1 x 420 W at 300 VDC	1 x 360 W at 300 VDC
Accuracy		
$R_{load} \geq 250 \Omega$ , $U_{L-N} = 0 \dots 300V$	Error < 0.015 % of rd. <sup>5</sup> + 0.005 % of rg.	Error < 0.04 % of rd. + 0.01 % of rg.
$R_{load} < 250 \Omega$ $U_{L-N} \geq 30 V$ $U_{L-N} < 30 V$	Error < 0.025 % of rd. Error < 10mV	Error < 0.1 % of rd. Error < 30mV
Harmonic distortion (THD+N) <sup>6</sup>	0.015 %	< 0.05 %
DC offset voltage	< 20 mV	< 100 mV
Voltage ranges	Range I: 0 ... 150 V Range II: 0 ... 300 V	
Frequency ranges <sup>7</sup>	sinusoidal signals harmonics/interharm. <sup>8</sup> transient signals	10 ... 1000 Hz 10 ... 3000 Hz DC ... 3.1 kHz
Resolution	Range I: 5 mV Range II: 10 mV	
Short-circuit protect.	Unlimited for L - N	
Connection	4 mm/0.16 " banana connectors; amplifier connection socket $V_{L1}$ - $V_{L3}$	
Insulation	Reinforced insulation of power supply and all SELV interfaces	

<sup>8</sup> Signals above 1 kHz are only supported in selected software modules and are only available on the voltage outputs and the low level outputs.

### 6.3.5.1 Power Diagram for Three-Phase Operation

Figure 6-13:  
Power diagram for  
three-phase operation



### 6.3.5.2 Power Diagram for Single-Phase Operation

Also refer to section 7.6, "Single-Phase Voltage" on page 107.

Figure 6-14:  
Single-phase  
operation L-N

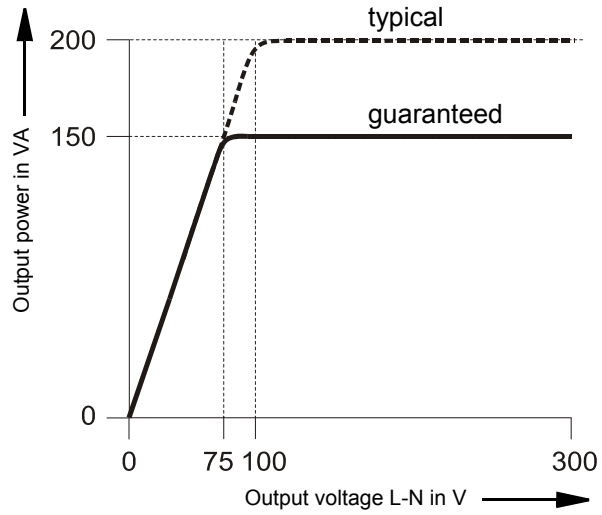
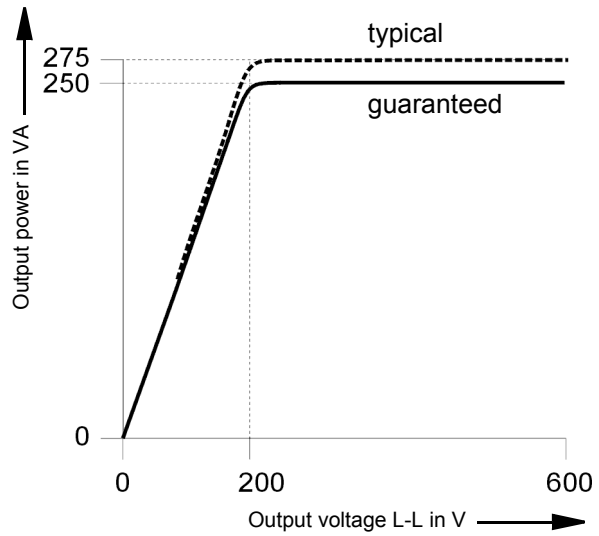


Figure 6-15:  
Single-phase  
operation L-L



### 6.3.6 Accuracy of Output Power

Table 6-9:  
Output power *CMC 256*

Output Power		
	Typical	Guaranteed
Accuracy <sup>1</sup>	Error < 0.05 %	Error < 0.1 %
Output power temperature drift	0.001 %/°C	< 0.005 %/°C

<sup>1</sup> Data are valid for set value (relative error) from 0.1 to 12.5 A (current amplifier A or B) and 50 to 300 V (voltage amplifier) at 50/60 Hz.

Permissible load for current outputs:

- Range 1.25 A: 0 to 1 Ω and 1 VA max., cos φ = 0.5 to 1
- Range 12.5 A: 0 to 0.5 Ω and 6 VA max., cos φ = 0.5 to 1

Permissible load for voltage outputs:

- 10 VA max. at 50 to 300 V, cos φ = 0.5 to 1

### 6.3.7 Operational Limits in Conjunction with a Weak Mains Supply Voltage

Principally, the maximum output power of the *CMC 256* is limited by the mains input supply voltage. If the input supply voltage is less than 115 V<sub>AC</sub>, it is no longer possible to drive all outputs (VOLTAGE OUTPUT, CURRENT OUTPUT, AUX DC) simultaneously at full load.

If all of the voltage and current outputs as well as the AUX DC output are to be driven with a supply voltage of less than 115 V<sub>AC</sub>, reduce the maximum load of the current outputs. To do so, use the **Hardware Configuration** of the *OMICRON Test Universe* software.

Beside the reduction of the available total output power of low line voltages, no other significant degradations in the technical data of the *CMC 256* occur.

### 6.3.8 Low Level Outputs "LL out" for External Amplifiers

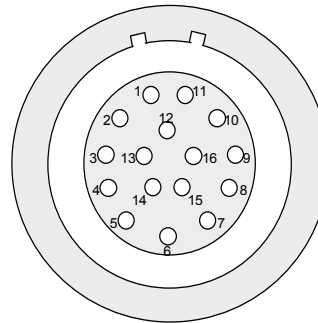
Both SELV interface connectors "LL out 1 - 6" as well as the optional "LL out 7 - 12" (if applicable) hold two independent generator triples each. These six high accuracy analog signal sources per connector can serve to either control an external amplifier or to directly provide small signal outputs.

In addition, each SELV interface connector provides a serial digital interface (pins 8-16; see below) that transmits control and monitor functions between the CMC 256 and the external amplifiers. Supported devices are the CMA 156, CMA 56, CMS 156, CMS 251 and CMS 252 (see also 9.8.7, "CMLIB A" on page 130 and 9.8.9, "Connection Cable for REF 54x Relays (ABB) with Low Level Signal Inputs" on page 132).

The low level outputs are short-circuit-proof and continually monitored for overload. They are separated through reinforced insulation from the power input and from the load outputs (SELV interface). They deliver calibrated signals in the range from 0 to 7  $V_{eff}$  nominal (0 to  $\pm 10 V_{peak}$ ).

Both the selection of the particular amplifier as well as the specification of the range of the amplifier takes place in the *Test Universe* software.

Figure 6-16:  
Pin assignment of  
"LL out 1-6" (lower 16-pole  
Lemo socket); view onto  
the connector from the  
cable wiring side



The pin assignment of  
"LL out 7-12" socket is  
identical.

Pin	Function LL out 1-6	Function LL out 7-12
Pin 1	LL out 1	LL out 7
Pin 2	LL out 2	LL out 8
Pin 3	LL out 3	LL out 9
Pin 4	Neutral (N) connected to GND	
Pin 5	LL out 4	LL out 10
Pin 6	LL out 5	LL out 11
Pin 7	LL out 6	LL out 12
Pin 8-16	For internal purposes	
Housing	Screen connection	

"LL out 1-3" and "LL out 4-6" (and optionally "LL out 7-9" and "LL out 10-12") each make up a selectable voltage or current triple.

Table 6-10:  
Data for SELV outputs  
"LL out"

6 Outputs "LL out 1 - 6" and 6 (optional) outputs "LL out 7 - 12"		
Output voltage range	0...±10 V <sub>peak</sub> <sup>1</sup> (SELV)	
Output current	Max. 1 mA	
Resolution	< 250 µV	
Accuracy	Typical < 0.025 %	Guaranteed < 0.07 % for 1...10 V <sub>peak</sub>
Harmonic distortion (THD+N) <sup>2</sup>	Typical < 0.015 %	Guaranteed < 0.05 %
DC offset voltage	Typical < 150 µV	Guaranteed < 1.5 mV
Unconventional CT/VT simulation	Linear or Rogowski <sup>3</sup> mode	
Overload indication	Yes	
Short-circuit protection	Unlimited to GND	
Insulation	Reinforced insulation to all other potential groups of the test equipment. GND is connected to protective earth (PE).	

<sup>1</sup> Input OMICRON amplifier nominal: 0 ... 5 V<sub>rms</sub>

<sup>2</sup> Values at nominal voltage (10 V<sub>peak</sub>), 50/60 Hz, and 20 kHz measurement bandwidth.

<sup>3</sup> When simulating Rogowski sensors, the output voltage is proportional to the derivative of the current with respect to time (di(t)/dt).

Table 6-11:  
Ordering Information

Ordering Information	
Connector for two guide notches and pull relief (for "LL out")	FGB.2B.316.CLAD 72Z
Black anti-bend cable cover	GMA.2B.070 DN

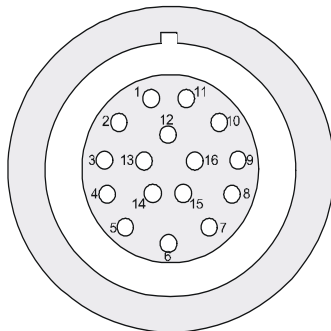
For a manufacturer description about the connection sockets "LL out" and "ext. Interf.", visit the Web site [www.lemo.com](http://www.lemo.com).

### 6.3.9 Low-Level Binary Outputs ("ext. Interf.")

The SELV interface connector "ext. Interf." holds four additional transistor binary outputs (Bin. out 11 - 14). Unlike regular relay outputs, Bin. out 11 - 14 are bounce-free binary outputs (small signals) and have a minimal reaction time.

In addition, two high frequency counter inputs for up to 100 kHz are available for the testing of energy meters. They are described in section 6.4.2, "Counter Inputs 100 kHz (Low Level)" on page 71.

Figure 6-17:  
Pin assignment of "ext. Interf." (upper 16-pole Lemo socket); view onto the connector from the cable wiring side



Pin	Function
Pin 1	Counter input 1
Pin 2	Counter input 2
Pin 3	Reserved
Pin 4	Neutral (N) connected to GND
Pin 5	Binary output 11
Pin 6	Binary output 12
Pin 7	Binary output 13
Pin 8	Binary output 14
Pin 9	Reserved
Housing	Screen connection

Table 6-12:  
Data of the low-level binary outputs 11 - 14

4 Low-Level Transistor Binary Outputs (Bin. out 11 - 14)	
Type	Open-collector transistor outputs; external pull-up resistor
Switching voltage	Max. 15 V
Max. input voltage	±16 V
Switch current	Max. 5 mA (current limited); min. 100 µA
Actualization time	100 µs
Rise time	< 3 µs ( $V_{\text{extern}} = 5 \text{ V}$ , $R_{\text{pullup}} = 4.7 \text{ k}\Omega$ )
Connection	Connector "ext. Interf." (CMC 256 rear side)
Insulation	Reinforced insulation to all other potential groups of the test equipment. GND is connected to protective earth (PE).



Figure 6-18:  
Circuit diagram of  
"ext. Interf." binary  
transistor outputs 11 - 14

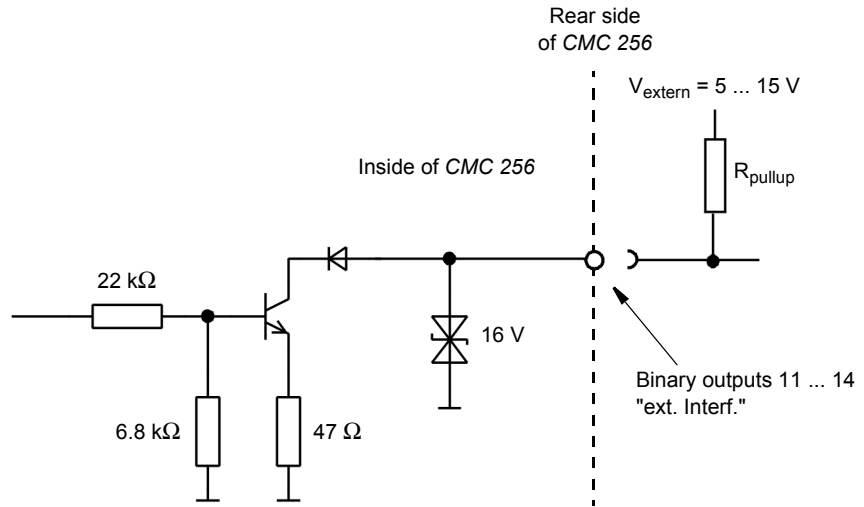


Table 6-13:  
Ordering Information

Ordering Information	
Connector for one guide notch and pull relief (for "ext. Interf")	FGG.2B.316.CLAD 72Z
Black anti-bend cable cover	GMA.2B.070 DN

For a manufacturer description about the connection sockets "LL out" and "ext. Interf.", visit the Web site [www.lemo.com](http://www.lemo.com).

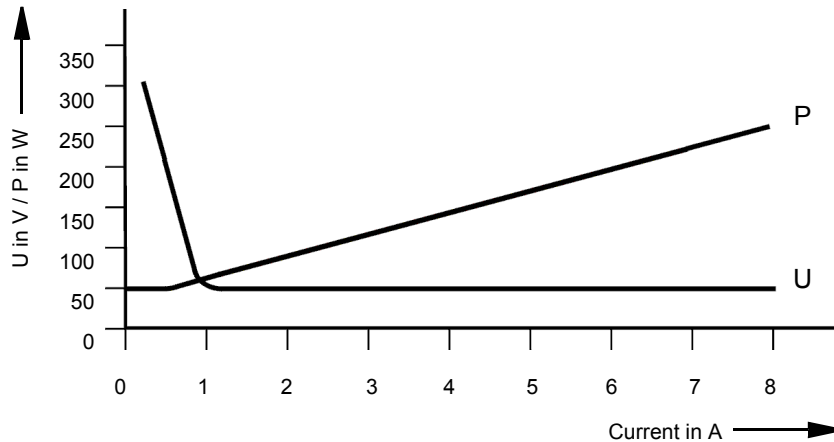
### 6.3.10 Binary Output Relays

Table 6-14:  
Data of binary output  
relays

4 Binary Output Relays (Binary Outputs 1-4)	
Type	Potential-free contacts; software-controlled
AC loading	$V_{max}$ 300 VAC; $I_{max}$ 8 A; $P_{max}$ 2000 VA
DC loading	$V_{max}$ 300 VDC; $I_{max}$ 8 A; $P_{max}$ 50 W (refer to load limit curve)
Switch-on current	15 A (max. 4 s at 10 % duty-cycle)
Electrical lifetime	100 000 switching cycles at 230 V <sub>AC</sub> / 8 A and ohmic load
Pickup time	Approx. 6 ms
Fall back time	Approx. 3 ms
Bounce time	Approx. 0.5 ms
Connection	4 mm/0.16 " banana sockets
Insulation	Reinforced insulation from all SELV interfaces and from power supply.

The accompanying diagram shows the load limit curve for DC voltages. For AC voltages, a maximum power of 2000 VA is achieved.

Figure 6-19:  
Load limit curve for relays  
on the binary outputs with  
DC voltages



### 6.3.11 DC Supply (AUX DC)

Table 6-15:  
DC Voltage supply  
AUX DC

DC Supply (AUX DC)	
Voltage ranges	0 ... 66 V <sub>DC</sub> (max. 0.8 A) 0 ... 132 V <sub>DC</sub> (max 0.4 A) 0 ... 264 V <sub>DC</sub> (max. 0.2 A)
Power	Max. 50 W
Accuracy <sup>1</sup>	Error: typical < 2 %, guaranteed < 5 %
Resolution	< 70 mV
Connection	4 mm/0.16 " banana sockets on front panel
Short-circuit protection	Yes
Overload indication	Yes
Insulation	Reinforced insulation from power supply and all SELV interfaces

<sup>1</sup> Percentage is with respect to each range's full-scale.

## 6.4 Inputs

### 6.4.1 Binary Inputs

Table 6-16:  
General data of  
binary inputs

General Data of Binary Inputs 1...10	
Number of binary inputs	10
Trigger criteria	Potential-free or DC-voltage compared to threshold voltage
Reaction time	Max. 220 $\mu$ s
Sampling frequency	10 kHz
Time resolution	100 $\mu$ s
Max. measuring time	Unlimited
Debounce time	0...25 ms (refer to page 70)
Deglitch time	0...25 ms (refer to page 70)
Counting function counter frequency pulse width	3 kHz (per input) >150 $\mu$ s (for high and low signals)
Configuration	Binary inputs can be configured. Refer to the OMICRON <i>Test Universe</i> Help.
Connection	4 mm/0.16 " banana sockets on the front panel
Insulation	5 galvanic insulated binary groups with each 2 inputs having its own GND. Operation insulation to the power outputs, DC inputs and between galvanically separated groups. Reinforced insulation from all SELV interfaces and from power supply.

Table 6-17:  
Data for potential-sensing  
operation

Data for Potential-Sensing Operation		
Threshold voltage data per input range	Setting range	Resolution
100 mV	$\pm 140$ mV	2 mV
1 V	$\pm 1.4$ V	20 mV
10 V	$\pm 14$ V	200 mV
100 V	$\pm 140$ V	2 V
600 V	$\pm 600$ V	20 V
Max. input voltage	CAT II / 600 V <sub>rms</sub> (850 V <sub>pk</sub> ) CAT III / 300 V <sub>rms</sub> CAT IV / 150 V <sub>rms</sub>	
Threshold voltage accuracy <sup>1</sup> per range: 100 mV, 1 V, 10 V, 100 V, 600 V	Error: typical < 2 %, guaranteed < 4 % typical < 5 %, guaranteed < 10 %	
Threshold voltage hysteresis	1 ... 5 % of the specified input in reference to each range's scale	
Input impedance <sup>2</sup>	500 k $\Omega$ ( $\parallel$ 50 pF)	

<sup>1</sup> Valid for positive voltage signal edge; percentage is shown in respect to each range's full-scale.

<sup>2</sup> Refer to figure 5-2 in section 5-2, "Simplified diagrams of analog and binary inputs and outputs" on page 30.

Table 6-18:  
Data for potential-free  
operation

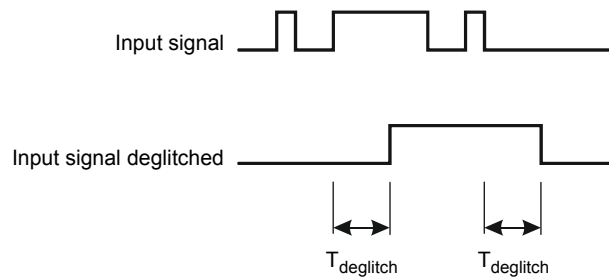
Data for Potential-Free Operation <sup>1</sup>	
Trigger criteria	Logical 0: R > 80 k $\Omega$ Logical 1: R < 40 k $\Omega$
Input impedance	162 k $\Omega$ ( $\parallel$ 50 pF)

<sup>1</sup> Refer to figure 5-2 in section 5-2, "Simplified diagrams of analog and binary inputs and outputs" on page 30.

### Deglitching input signals

In order to suppress short spurious pulses a deglitching algorithm could be configured. The deglitch process results in an additional dead time and introduces a signal delay. In order to be detected as a valid signal level, the level of an input signal must have a constant value at least during the deglitch time. The figure below illustrates the deglitch function.

Figure 6-20:  
Signal curve, deglitching  
input signals



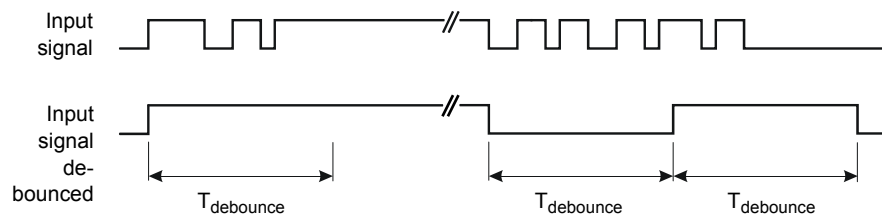
### Debouncing input signals

For input signals with a bouncing characteristic, a debounce function can be configured. This means that the first change of the input signal causes the debounced input signal to be changed and then be kept on this signal value for the duration of the debounce time.

The debounce function is placed after the deglitch function described above and both are realized by the firmware of the *CMC 256* and are calculated in real time.

The figure below illustrates the deglitch function. On the right-hand side of the figure, the debounce time is too short. As a result, the debounced signal rises to “high” once again, even while the input signal is still bouncing and does not drop to low level until the expiry of another period  $T_{debounce}$ .

Figure 6-21:  
Signal curve, debounce  
input signals

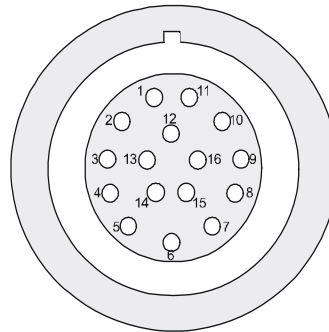


## 6.4.2 Counter Inputs 100 kHz (Low Level)

The SELV interface connector "ext. Interf." holds two high frequency counter inputs for up to 100 kHz are available for the testing of energy meters.

In addition, four additional transistor binary outputs (Bin. out 11 - 14) are available. They are described in section 6.3.9, "Low-Level Binary Outputs ("ext. Interf.")" on page 64.

Figure 6-22:  
Pin assignment of "ext. Interf." (upper 16-pole Lemo socket); view onto the connector from the cable wiring side



Pin	Function
Pin 1	Counter input 1
Pin 2	Counter input 2
Pin 3	Reserved
Pin 4	Neutral (N) connected to GND
Pin 5	Binary output 11
Pin 6	Binary output 12
Pin 7	Binary output 13
Pin 8	Binary output 14
Pin 9	Reserved
Housing	Screen connection

Table 6-19:  
Counter inputs 100 kHz

2 Counter Inputs	
Max. counter frequency	100 kHz
Pulse width	> 3 $\mu$ s (high and low signal)
Switch threshold pos. edge neg. edge	max. 8 V min. 4 V
Hysteresis	typ. 2 V
Rise & fall times	< 1 ms
Max. input voltage	$\pm$ 30 V
Connection	Socket "ext. Interf." (rear CMC 256)
Insulation	Reinforced insulation to all other potential groups of the test equipment. GND is connected to protective earth (PE).

Figure 6-23:  
Circuit diagram of  
"ext. Interf." counter inputs  
1 and 2

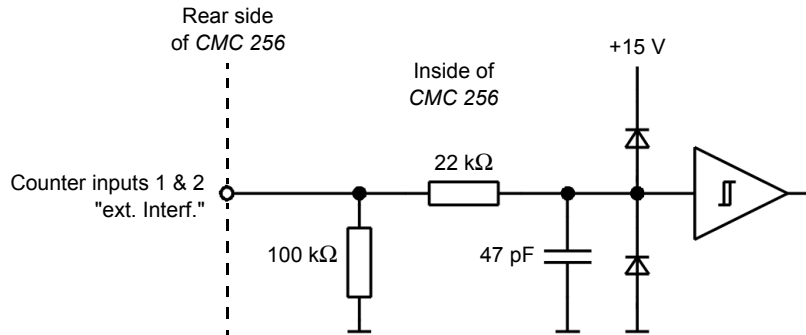


Table 6-20:  
Ordering Information

Ordering Information	
Connector for one guide notch and pull relief (for "ext. Interf.")	FGG.2B.316.CLAD 72Z
Black anti-bend cable cover	GMA.2B.070 DN

For a manufacturer description about the connection sockets "LL out 1-6" and "ext. Interf.", visit the Web site [www.lemo.com](http://www.lemo.com).



### 6.4.3 DC Measurement Inputs (ANALOG DC INPUT)

**Note:** Exceeding the specified input values can damage the measurement inputs!

Table 6-21:  
DC measurement input

DC Measurement Input IDC		
Measurement range	0 ... ±1 mA 0 ... ±20 mA	
Max. input current	600 mA	
Accuracy	Typical error < 0.003 % of rg. <sup>1</sup>	Guarant. error < 0.02 % of rg.
Input impedance	Approx. 15 Ω	
Connection	4 mm/0.16 " banana connectors	
Insulation	Insulation to all other front panel connections; reinforced insulation from all SELV interfaces and from power supply. Galvanically connected to V <sub>DC</sub> .	

<sup>1</sup> rg. = range, whereat *n* % of rg. means: *n* % of upper range value.

Table 6-22:  
DC voltage measurement  
input

DC Voltage Measurement Input VDC		
Measurement range	0...± 10 V	
Max. input voltage	± 11 V	
Input impedance	1 MΩ	
Max. input current	± 90 mA	
Accuracy	Typical error < 0.003 % of rg.	Guarant. error < 0.02 % of rg.
Connection	4 mm/0.16 " banana connectors	
Insulation	Galvanically connected to I <sub>DC</sub>	

## 6.5 Technical Data of the Ethernet Ports

Originally, *CMC 256* test sets were delivered with a so-called NET-1 board that holds two different Ethernet ports:

ETH1: a 10/100Base-TX Ethernet port

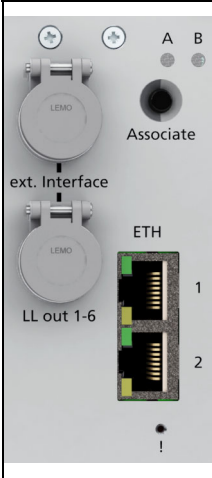
ETH2: a 100Base-FX (optical fiber) Ethernet port.

With the introduction of the front panel control device *CMControl*, the *CMC 256* test sets are now equipped with a NET-1B board that holds two identical PoE (Power over Ethernet) ports ETH1 and ETH2.

*CMC 256* test sets with NET-1 board can be upgraded with the new NET-1B board to be able to communicate with the new *CMControl* and have Ethernet access at the same time.

In addition, *CMC 256* test sets with PAR-1 option (parallel printer port) can be upgraded with a NET-1B board, too.

### 6.5.1 The NET-1B Board

Ethernet ports ETH1 and ETH2		
	Type	10/100Base-TX (10/100Mbit, twisted pair, auto-MDI/MDIX or auto-crossover)
	Connector	RJ45
	Cable type	LAN cable of category 5 (CAT5) or better
	Status indication	Green LED: physical link present Yellow LED: traffic on interface
	Power over Ethernet (PoE)	IEEE 802.3af compliant. Port capability limited to one Class 1 (3.84 W) and one Class 2 (6.49 W) power device.

## 6.5.2 The NET-1 Board

Table 6-23:  
Technical data of the  
NET-1 Ethernet port ETH1


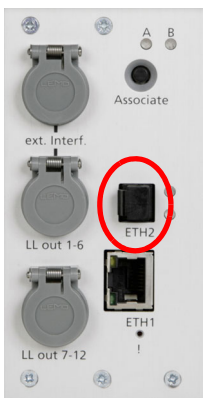

Ethernet port ETH1		
	Type	10/100Base-TX (10/100Mbit, twisted pair, auto-MDI/MDIX or auto-crossover)
	Connector	RJ45
	Cable type	LAN cable of category 5 (CAT5) or better
	Status indication	Green LED: physical link present Yellow LED: traffic on interface

Table 6-24:  
Technical data of the  
NET-1 Ethernet port ETH2

Ethernet port ETH2		
	Type	100Base-FX (100Mbit, fiber, duplex)
	Connector	MT-RJ
	Cable type	50/125 $\mu\text{m}$ or 62.5/125 $\mu\text{m}$ (duplex patch cable)
	Cable length	> 1 km (0.62 miles) possible
	Status indication	Green LED: physical link present Yellow LED: traffic on interface
		This is a product of Laser Class 1 (IEC 60825)

## 6.6 Environmental Conditions

### 6.6.1 Climate

Table 6-25:  
Climate

Climate	
Operating temperature	0 ... +50 °C; above +30 °C a 50 % duty cycle may apply.
Storage and transportation	-25 ... +70 °C
Max. altitude	2000 m
Humidity	5 ... 95% relative humidity; no condensation
Climate	Tested according to IEC 68-2-78

### 6.6.2 Shock and Vibration

Table 6-26:  
Shock and vibration

Dynamics	
Vibration	Tested according to IEC 68-2-6 (operating mode); frequency range 10 ... 150 Hz; acceleration 2 g continuous (20 m/s <sup>2</sup> ); 10 cycles per axis
Shock	Tested according to IEC 68-2-27 (operating mode); 15 g / 11 ms, half-sinusoid, each axis

## 6.7 Mechanical Data

Table 6-27:  
Data regarding size and weight



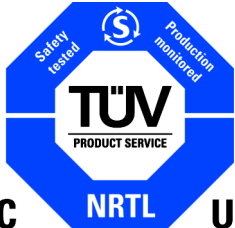

Size, Weight and Protection	
Weight	15.9 kg (35 lbs)
Dimensions W x H x D (without handle)	450 x 145 x 390 mm (17.7 x 5.7 x 15.4 ")
Housing	IP20 according to EN 60529

## 6.8 Cleaning

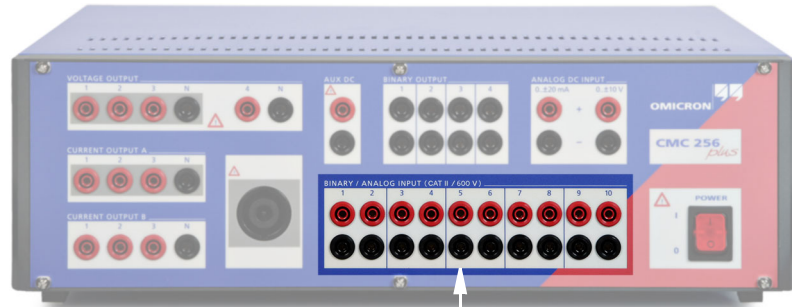
To clean the *CMC 256*, use a cloth dampened with isopropanol alcohol or water.

## 6.9 Safety Standards, Electromagnetic Compatibility (EMC) and Certificates

Table 6-28:  
CE conformity, certified  
Safety Standards and  
EMC-compatibility

CE Conformity, Requirements	
The product adheres to the specifications of the guidelines of the council of the European Community for meeting the requirements of the member states regarding the electromagnetic compatibility (EMC) Directive 89/336/EEC and the low voltage Directive 73/23/EEC.	
EMC	
Emission	
Europe	EN 61326; EN 61000-6-4; EN 61000-3-2/3
International	IEC 61326; IEC 61000-6-4; IEC 61000-3-2/3
USA	FCC Subpart B of Part 15 Class A
Immunity	
Europe	EN 61326; EN 61000-6-2; EN 61000-4-2/3/4/5/6/11
International	IEC 61326; IEC 61000-6-2; IEC 61000-4-2/3/4/5/6/11
Certified Safety Standards	
Europe	EN 61010-1 Insulation of PC and SELV interfaces complies with EN 60950-1
International	IEC 61010-1
USA	UL 61010-1
Canada	CAN/CSA-C22.2 No 61010-1-04
Certificate	   
Manufactured under an ISO9001 registered system	

## 6.10 The *EnerLyzer* Measurement Option



Binary/analog inputs of *CMC 256plus*

Optionally, each of the ten binary/analog inputs of the *CMC 256* can be configured as **analog measurement inputs** for DC and AC voltages up to 600 V.

Voltage and current measurements on three channels is basic functionality of the *CMC 256* test set. The fully featured measurement functionality on all ten channels requires the *EnerLyzer* option

As the analog inputs of the *CMC 256* are voltage inputs, active current clamps with voltage outputs have to be used to measure currents.

OMICRON offers the *C-PROBE1* as a suitable current clamp (refer to section 9.7, "Current Clamp C-PROBE1" on page 123). This current clamp is not included in the deliverables of the *EnerLyzer* measurement option. Please order it separately.

For questions, please contact OMICRON (refer to section "Contact Information / Technical Support" on page 149).

The *EnerLyzer* option contains:

- The *EnerLyzer* software module that can be started from within the OMICRON *Test Universe* software.
- The "*EnerLyzer*" software manual in PDF format.

### 6.10.1 General Data

The analog measurement inputs have five measurement ranges that can be individually configured in the test module *EnerLyzer*.

- 100 mV
- 1 V
- 10 V
- 100 V
- 600 V

These range limits refer to the respective rms values of the sinusoidal shaped input signals. The ranges 100 mV, 1 V, 10 V and 100 V could be overloaded approximately with 10 %.

Input impedance: 500 kOhm // 50 pF for all measurement ranges.

Overload protection: 600 Vrms ( $\pm 850$  Vpeak) from reference potential N, from another input, or protective earth (GND).

The sampling rate can be configured by software:

- 28.44 kHz
- 9.48 kHz
- 3.16 kHz

Four different operating modes are possible:

- Multimeter Mode (section 6.10.2)
- Harmonic Analysis (section 6.10.3)
- Transient Recording (section 6.10.4)
- Trend Recording (section 6.10.5)

### 6.10.2 Multimeter Mode

This operating mode is designed for measuring steady-state signals (e.g., also non-sinusoidal shaped). Measurements such as rms values, phase angle, frequency, etc. can be made.

The input signals are processed in real time without delay.

### 6.10.2.1 Accuracy AC Measurements

Conditions: integration time 1 s, measurement signal sinusoidal, excitation 10 - 100 %, accuracy references the measurement full scale values.

Table 6-29:  
Sampling rate 28.44 kHz,  
measurement range  
600 V, 100 V, 10 V, 1 V

Frequency range	Accuracy	
	Typical	Guaranteed
DC	± 0.15%	± 0.40%
10 Hz ... 100 Hz	± 0.06%	± 0.15%
10 Hz ... 1 kHz	+ 0.06% / -0.11%	± 0.25%
10 Hz ... 10 kHz	+ 0.06% / -0.7%	± 1.1%

Table 6-30:  
Sampling rate 28.44 kHz,  
measurement range  
100 mV

Frequency range	Accuracy	
	Typical	Guaranteed
DC	± 0.15%	± 0.45%
10 Hz ... 100 Hz	± 0.1%	± 0.3%
10 Hz ... 1 kHz	+ 0.15% / -0.2%	± 0.5%
10 Hz ... 10 kHz	+ 0.15% / -1.0%	± 2%

Table 6-31:  
Sampling rate  
9.48 kHz  
3.16 kHz  
measurement range  
600 V, 100 V, 10 V, 1 V

Frequency range	Accuracy	
	Typical	Guaranteed
DC	± 0.15%	± 0.45%
10 Hz ... 100 Hz	± 0.08%	± 0.2%
10 Hz ... 1 kHz	+ 0.1% / -0.3%	± 0.5%
10 Hz ... 4 kHz (sampling rate 9.48 kHz)	+ 0.1% / -0.5%	± 1.2%
10 Hz ... 1.4 kHz (sampling rate 3.16 kHz)	+ 0.1% / -0.5%	± 1.0%

Table 6-32:  
Sampling rate  
9.48 kHz  
3.16 kHz  
measurement range  
100 mV

Frequency range	Accuracy	
	Typical	Guaranteed
DC	± 0.15%	± 0.5%
10 Hz ... 100 Hz	± 0.1%	± 0.35%
10 Hz ... 1 kHz	+ 0.15% / -0.35%	± 0.5%
10 Hz ... 4 kHz (sampling rate 9.48 kHz)	+ 0.15% / -0.6%	± 1.2%
10 Hz ... 1.4 kHz (sampling rate 3.16 kHz)	+ 0.15% / -0.6%	± 1.2%



The accuracy data contains linearity, temperature, long-term drift, and frequency.

Figure 6-24:  
Typical frequency response with a sampling rate of 28.44 kHz and an input voltage of 70 V<sup>1</sup>

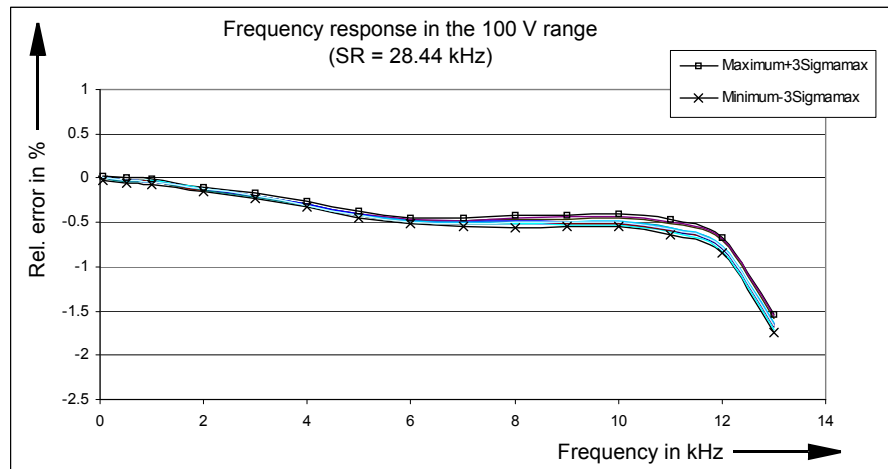
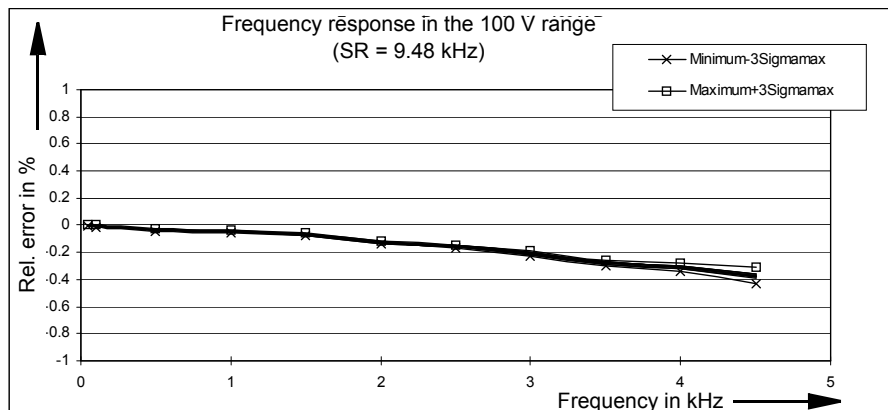


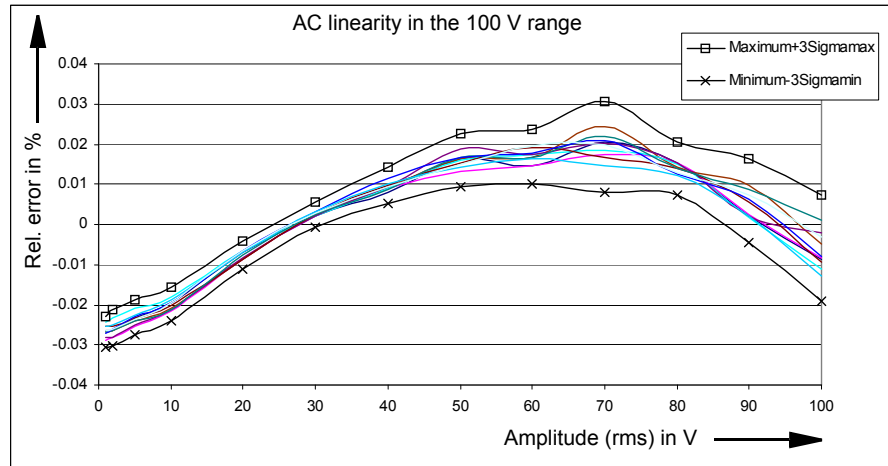
Figure 6-25:  
Typical frequency response with a sampling rate of 9.48 kHz and an input voltage of 70 V<sup>1</sup>



<sup>1</sup> a) Relative error:  $\frac{\text{Actual} - \text{Expected}}{\text{Full scale}} \times 100 \%$

b) 3Sigma<sub>max</sub> represents the maximum of the 3Sigma values of all 10 input channels. The 3Sigma<sub>max</sub> value of an analog input are determined from 50 measurement values.

Figure 6-26:  
 Typical AC linear  
 progression at 50 Hz and a  
 sampling rate of  
 28.44 kHz<sup>1</sup>



$$^1 \text{ a) Relative error: } \frac{\text{Actual} - \text{Expected}}{\text{Full scale}} \times 100 \%$$

- b) 3Sigma<sub>max</sub> represents the maximum of the 3Sigma values of all 10 input channels. The 3Sigma<sub>max</sub> value of an analog input are determined from 50 measurement values.

### 6.10.2.2 Channel Cross-Talk

Conditions: sinusoidal form infeed on a channel without overload, AC measurement on neighboring channel, integration time 1 s.

Table 6-33:  
Cross talk dampening

Measurement range	600 V	100 V	10 V	1 V	100 mV
Dampening in dB	80	105	95	120	120

Cross talk dampening on channels of the same potential groups in dB at  $f = 50 \text{ Hz}$

Table 6-34:  
Cross talk dampening

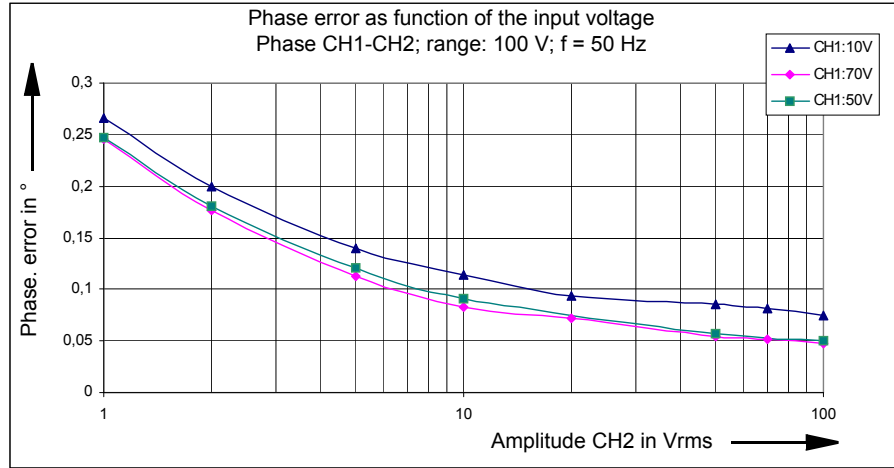
Measurement range	600 V	100 V	10 V	1 V	100 mV
Dampening in dB	65	80	75	95	95

Cross talk dampening on channels of the same potential groups in dB at  $f = 500 \text{ Hz}$

The cross-talk dampening on a neighboring channel of another potential group is greater than 120 dB in all measurement ranges ( $f = 50 \text{ Hz}$  or  $500 \text{ Hz}$ ).

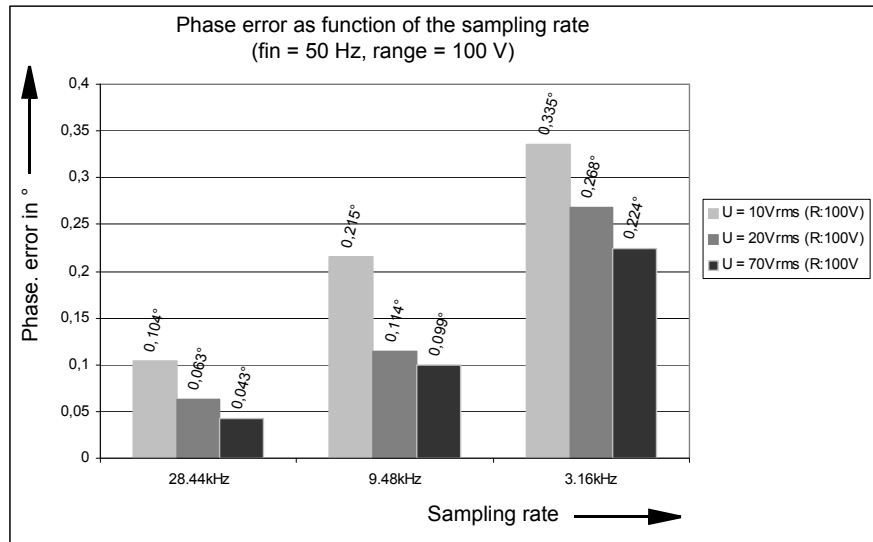
### 6.10.2.3 Accuracy Phase Measurement

Figure 6-27:  
Phase error as function of  
input voltage



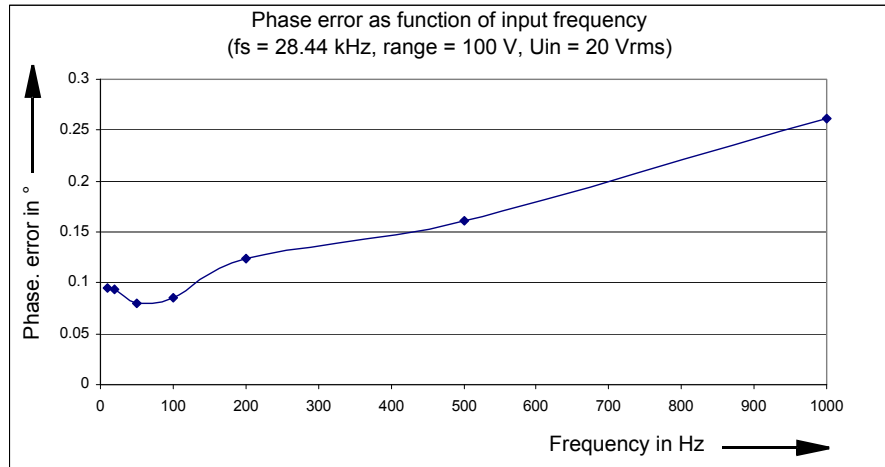
Conditions: integration time 1 s, measurement signal sinusoidal, measurement range 100 V, f = 50 Hz, sampling rate 28.44 kHz.

Figure 6-28:  
Phase error as function of  
sampling rate



Conditions: integration time 1 s, measurement signal sinusoidal, f = 50 Hz, measurement range 100 V, both channels same excitation (20 V, 70 V).

Figure 6-29:  
Typical phase error as  
function of the input  
frequency



Conditions: integration time 1 s, measurement signal sinusoidal, sampling rate = 28.44 kHz, measurement range 100 V, excitation on both channels 20 Vrms.

The maximum input frequency for the phase measurement depends on the sampling rate.

Table 6-35:  
Sampling rate and input  
frequency range

Sampling rate	Input frequency range
28.44 kHz	10 Hz ... 2.30 kHz
9.48 kHz	10 Hz ... 750 Hz
3.16 kHz	10 Hz ... 250 Hz

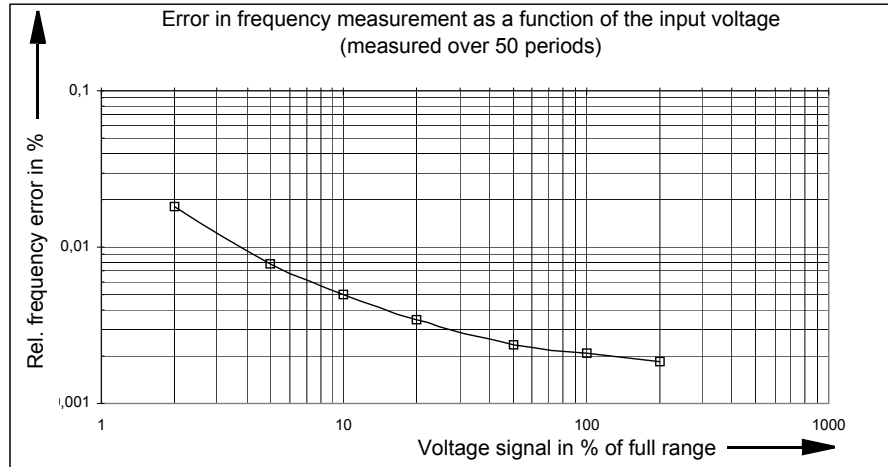


**Note:**

1. The measurement accuracy of phase can be improved by:
  - increasing the integration time
  - enabling the recursive averaging function
2. When measuring very small phase shifts (less than 0.2 °), the sign (positive or negative) of the measurement results can not be definitely determined. If this causes a problem, please refer to the phase measurement in the harmonic analysis.
3. For measuring phase, the input voltage should be greater than 5 % of full scale. An overload of the measurement channel does not negatively affect the obtainable accuracy.

### 6.10.2.4 Accuracy of the Frequency Measurement

Figure 6-30:  
Error in the frequency measurement as a function of the input voltage



Conditions: integration time 1 s, measurement signal sinusoid.

The maximum input frequency for the frequency measurement depends on the sampling rate.

Table 6-36:  
Sampling rate and input frequency range.

Sampling rate	Input frequency range
28.44 kHz	10 Hz ... 1500 Hz
9.48 kHz	5 Hz ... 500 Hz
3.16 kHz	5 Hz ... 150 Hz

Conditions: Excitation greater than 10 % from measurement full scale, duty cycle 50 %.



**Note:** With the harmonic analysis, input frequencies up to 3.4 kHz can be measured.

### 6.10.2.5 Accuracy of Power Measurement

#### General

The power is calculated from one current channel and one voltage channel:

$$\text{Active power: } P = \frac{1}{T} \int_0^T u(t) \cdot i(t) dt \text{ [W]}$$

$$\text{Apparent power: } S = V_{\text{rms}} \times I_{\text{rms}} \text{ [VA]}$$

$$\text{Reactive power: } Q = \sqrt{S^2 - P^2} \cdot \text{sign}_Q \text{ [var]}$$

$$U_{\text{rms}} = \sqrt{\frac{1}{T} \int_0^T u(t)^2 dt} \quad , \quad I_{\text{rms}} = \sqrt{\frac{1}{T} \int_0^T i(t)^2 dt}$$

#### Accuracies

Conditions: integration time 1s, measurement signal sinusoidal, excitation 10-100 %, accuracy references the apparent power, error of the current clamp is not taken into consideration

Table 6-37:  
Sampling rates  
28.44kHz  
9.48kHz  
3.16kHz

Frequency range	Power	Accuracy <sup>1</sup>	
AC		Typical	Guaranteed
10 Hz ... 100 Hz	S	± 0.3 %	± 0.7 %
	P	± 0.3 %	± 0.7 %
	Q	± 0.8 %	± 2 %

Table 6-38:  
Sampling rate  
28.44kHz

Frequency range	Power	Accuracy <sup>1</sup>	
AC		Typical	Guaranteed
10 Hz ... 2.2 kHz	S	+ 0.3 % / - 1.2 %	± 2.5 %
	P	+ 0.3 % / - 1,2 %	± 2.5 %
	Q	+ 0.8 % / - 2.5 %	± 3.5 %

<sup>1</sup> Relative error:  $\frac{\text{Actual} - \text{Expected}}{\text{Full scale}} \times 100 \%$

S = Apparent power  
P = Active power  
Q = Reactive power

Table 6-39:  
Sampling rate  
9.48 kHz

Frequency range	Power	Accuracy <sup>1</sup>	
		Typical	Guaranteed
AC			
10 Hz ... 750 Hz	S	+ 0.3 % / - 0.7 %	± 1.8 %
10 Hz ... 750 Hz	P	+ 0.3 % / - 0.7 %	± 1.8 %
10 Hz ... 750 Hz	Q	+ 0.8 % / - 1.2 %	± 2.5 %

Table 6-40:  
Sampling rate  
3.16 kHz

Frequency range	Power	Accuracy <sup>1</sup>	
		Typical	Guaranteed
AC			
10 Hz ... 250 Hz	S	+ 0.3 % / - 0.5 %	± 1.3 %
10 Hz ... 250 Hz	P	+ 0.3 % / - 0.5 %	± 1.3 %
10 Hz ... 250 Hz	Q	+ 0.8 % / - 1 %	± 2.2 %

Table 6-41:  
DC accuracy

	Power	Accuracy <sup>1</sup>	
DC		Typical	Guaranteed
	P, S	± 0.3 %	± 0.9 %

$$^1 \text{ Relative error: } \frac{\text{Actual} - \text{Expected}}{\text{Full scale}} \times 100 \%$$

S = Apparent power  
P = Active power  
Q = Reactive power



**Note:** The accuracy specifications include linearity, temperature, ageing drift, frequency and phase response.



Typical relative error as function of the excitation

Figure 6-31:  
 Typical error of the  
 apparent power S as  
 function of the excitation,  
 $f_s = 28.44 \text{ kHz}$ ,  $f_{in} = 50 \text{ Hz}$

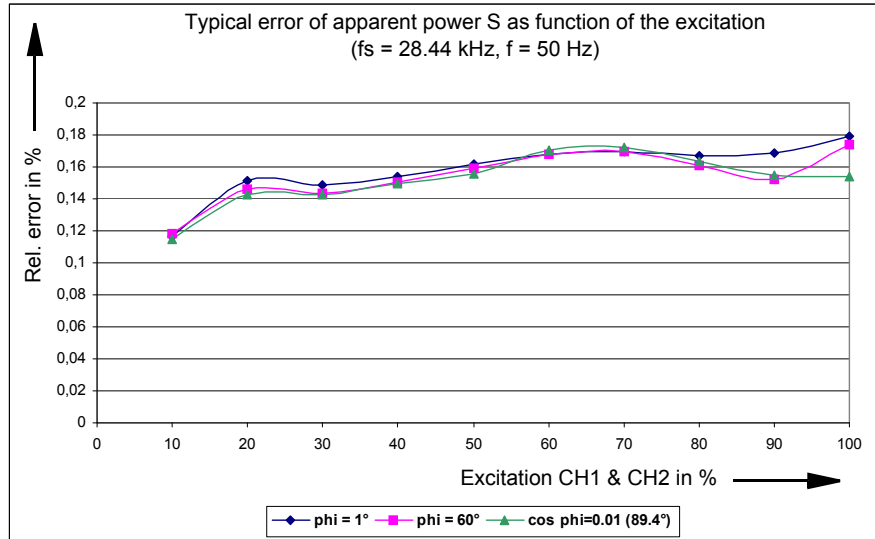


Figure 6-32:  
 Typical error of the active  
 power P as function of the  
 excitation considering the  
 apparent power,  
 $f_s = 28.44 \text{ kHz}$ ,  $f_{in} = 50 \text{ Hz}$

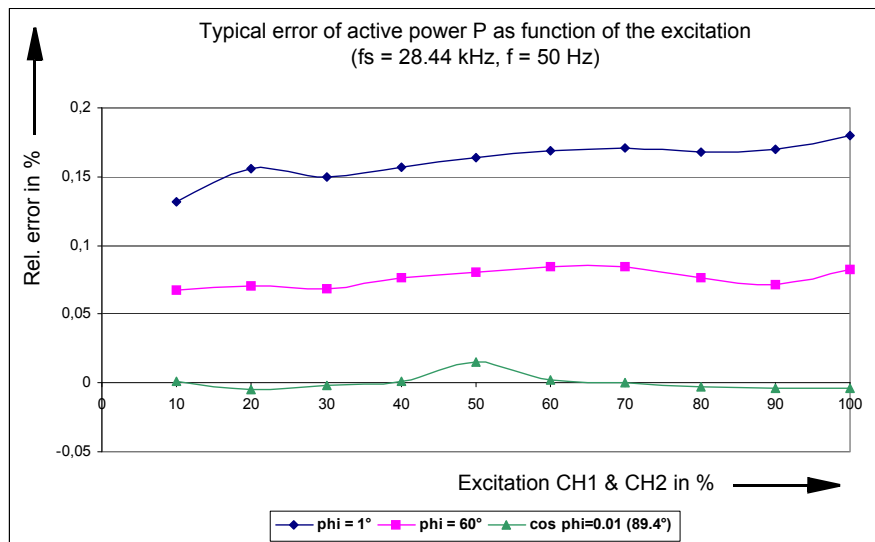
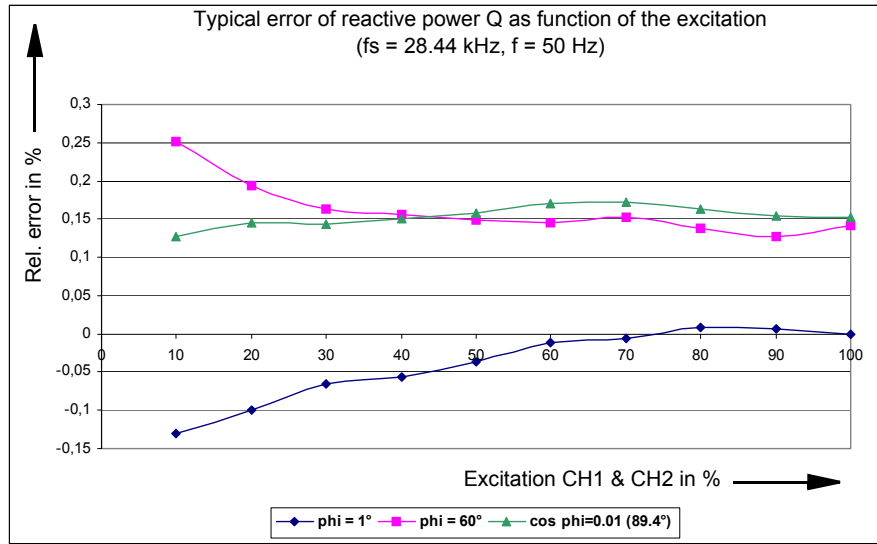
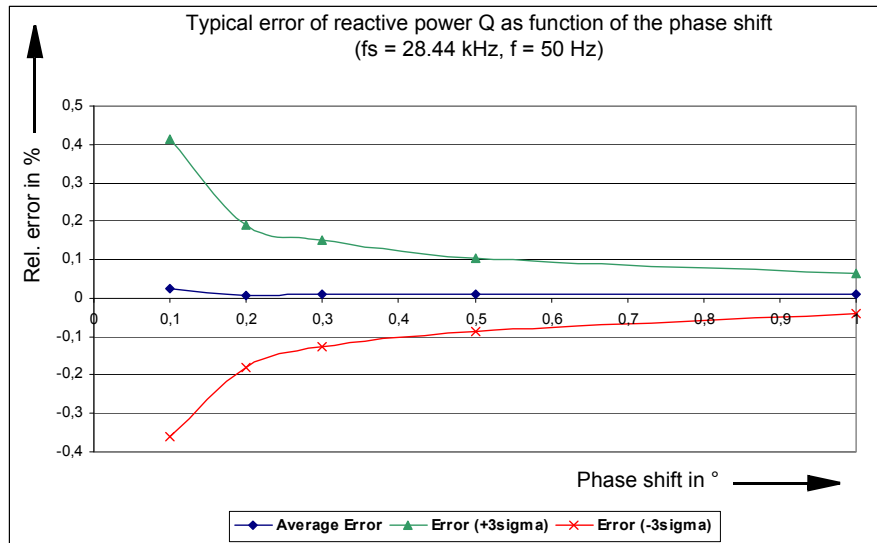


Figure 6-33:  
Typical error of the reactive power Q as function of the excitation,  $f_s = 28.44 \text{ kHz}$ ,  $f_{in} = 50 \text{ Hz}$



Conditions: integration time 1s, measurement signal sinusoid, sampling rate = 28.44 kHz,  $f_{in} = 50 \text{ Hz}$

Figure 6-34:  
Typical error<sup>1</sup> of the reactive power Q as function of the phase shift considering the apparent power,  $f_s = 28.44 \text{ kHz}$ ,  $f_{in} = 50 \text{ Hz}$ , excitation CH1 and CH2 = 70 %.



Conditions: integration time 1s, measurement signal sinusoidal, sampling rate = 28.44 kHz, both channels with same excitation 70 %

<sup>1</sup> The 3Sigma values are determined from 50 measurement values.

**Note:**

- For very small phase shifts ( $< 0,3^\circ$ ) and small excitation ( $< 10\%$ ), too small integration time ( $< 1\text{ s}$ ) or sampling rate  $3.16\text{ kHz}$ , the sign of the reactive power cannot definitely be determined.
- The accuracy of the power measurement depends primarily on the accuracy of the current clamp (refer to section 9.7, "Current Clamp C-PROBE1" on page 123).

**6.10.3 Harmonic Analysis**

This operating mode is designed for measuring stationary signals (e.g., not sinusoid shaped). The input signal is separated into fundamental and harmonic waves (Fourier Analysis).

The following items are measured:

- frequency of the fundamental wave
- amplitude of the fundamental and harmonic waves
- phase shifts between the fundamental and harmonic waves (also from the different channels)

The input signals are captured. Finally, the calculation of the measurement items is carried out. During this time, the input signal is not taken into consideration.

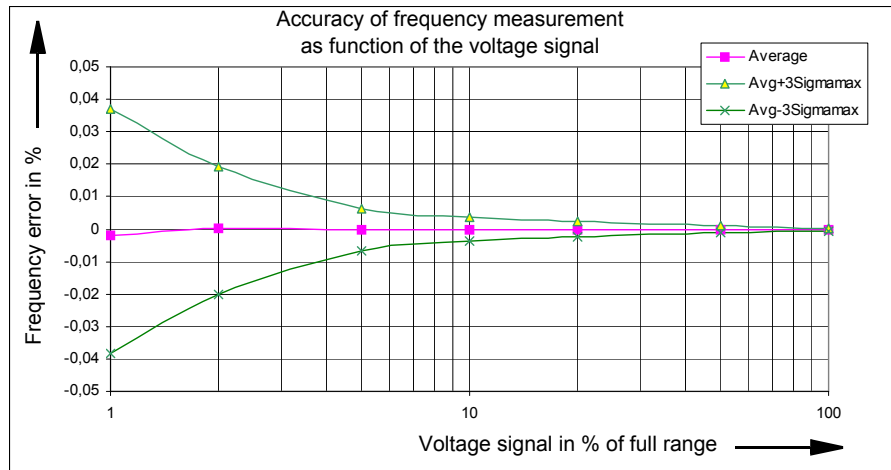
### 6.10.3.1 Accuracy of the Frequency Measurement

The permitted input frequency range depends on the specified sampling rate:

Table 6-42:  
Sampling rate and input frequency range

Sampling rate	Input frequency range
28.44 kHz	49 Hz ... 3400 Hz
9.48 kHz	17 Hz ... 1100 Hz
3.16 kHz	5 Hz ... 380 Hz

Figure 6-35:  
Accuracy of frequency measurement as function of the voltage signal



Conditions: sampling rate 9.48 kHz,  $f_{in}=20$  Hz ... 1 kHz



**Note:** Through recursive averaging, the measurement uncertainty can be further reduced.

### 6.10.3.2 Accuracy Amplitude Measurement

The measurement values are given as effective values (rms).

The permitted input frequency range for the fundamental wave depends on the specified sampling rate:

Table 6-43:  
Sampling rate and input  
frequency range

Sampling rate	Input frequency range
28.44 kHz	100 Hz (= fmin) ... 3200 Hz
9.48 kHz	30 Hz (= fmin) ... 1000 Hz
3.6 kHz	10 Hz (= fmin) ... 350 Hz

Valid for fundamental and harmonic waves in specified frequency range; accuracy refers to full scale.

Table 6-44:  
Sampling rate 28.44 kHz;  
measurement range  
600 V, 100 V, 10 V, 1 V

Frequency range	Accuracy	
	Typical	Guaranteed
fmin ... 1 kHz	± 0.1 %	± 0.3 %
fmin ... 10 kHz	+ 0.1 % / - 0.7 %	± 1.1 %

Table 6-45:  
Sampling rate 28.44 kHz;  
measurement range  
100 mV

Frequency range	Accuracy	
	Typical	Guaranteed
fmin ... 1 kHz	± 0.2 %	± 0.5 %
fmin ... 10 kHz	+ 0.2 % / - 1.0 %	± 2.0 %

Table 6-46:  
Sampling rate  
9.48 kHz  
3.16 kHz;  
measurement range  
600 V, 100 V, 10 V, 1 V

Frequency range	Accuracy	
	Typical	Guaranteed
fmin ... 100 Hz	± 0.1 %	± 0.3 %
fmin ... 1 kHz	+ 0.1 % / - 0.5 %	± 0.8 %
fmin ... 4 kHz (sampling rate = 9.48 kHz)	+ 0.1 % / - 0.8 %	± 1.2 %
fmin ... 1.4 kHz (sampling rate = 3.16 kHz)	+ 0.1 % / - 0.8 %	± 1.2 %

Table 6-47:  
Sampling rate  
9.48 kHz  
3.16 kHz;  
measurement range  
100 mV

Frequency range	Accuracy	
	Typical	Guaranteed
fmin ... 100 Hz	± 0.15 %	± 0.4 %
fmin ... 1 kHz	± 0.2 % / - 0.5 %	± 0.8 %
fmin ... 4 kHz (sampling rate = 9.48 kHz)	+ 0.2 % / - 1.0 %	± 1.5 %
fmin ... 1.4 kHz (sampling rate = 3.16 kHz)	+ 0.25 % / - 1.0 %	± 2.0 %

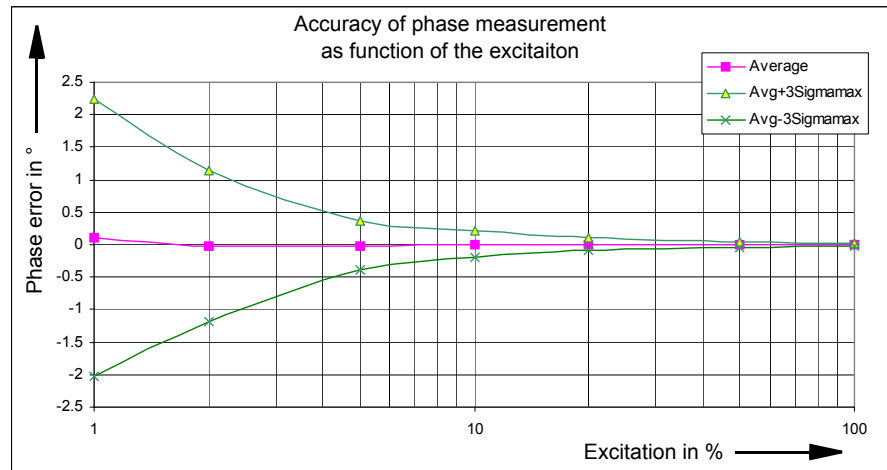
### 6.10.3.3 Accuracy of Phase Measurement

The permitted input frequency range for the fundamental wave depends on the specified sampling rate:

Table 6-48:  
Sampling rate and input  
frequency range

Sampling rate	Input frequency range
28.44 kHz	100 Hz ... 3200 Hz
9.48 kHz	30 Hz ... 1000 Hz
3.16 kHz	10 Hz ... 350 Hz

Table 6-49:  
Accuracy of phase  
measurement as function  
of the excitation



Conditions: sampling rate 9.48 kHz, fin = 50 Hz.



**Note:** Through recursive averaging, the measurement uncertainty can be reduced further.

### 6.10.4 Transient Recording

In this operating mode, transient signals on up to 10 input channels can be synchronously recorded.

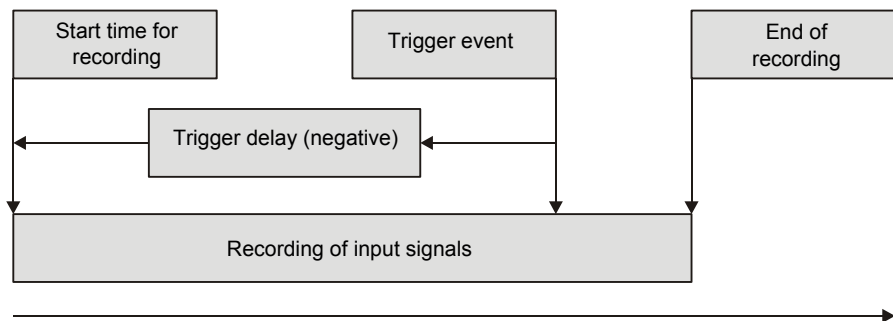
The recording starts whenever a pre-defined trigger condition is met. The selectable trigger conditions are:

- Trigger on threshold with positive or negative edge
- Combination of different power quality triggers (sag, swell, harmonic, frequency, frequency change, notch)

In addition, a time offset for the capture window relative to the trigger event can be specified. The trigger delay can be

- positive (recording begins after the trigger event)
- or negative (recording begins already before the trigger event).

Figure 6-36:  
Illustration of the  
relationship between  
trigger events, trigger  
delay, and recording time



**Note:** More details about triggering methods can be found in the OMICRON *Test Universe* Help and in the practical examples of the *EnerLyzer* option.

The maximum length of the recording depends on the settings for the sample rate and the number of channels to be captured.

Table 6-50:  
The maximum recording time depends on the number of active channels and the sampling frequency

Number of active channels	Maximum recording time [s] at fs = 28.4 kHz	Maximum recording time [s] at fs = 9.48 kHz	Maximum recording time [s] at fs = 3.16 kHz
1	35.16 s	105.47 s	316.41 s
2	17.58 s	52.73 s	158.20 s
3	11.72 s	35.16 s	105.47 s
4	8.79 s	26.37 s	79.10 s
5	7.03 s	21.09 s	63.28 s
6	5.86 s	17.58 s	52.73 s
7	5.02 s	15.07 s	45.20 s
8	4.40 s	13.18 s	39.55 s
9	3.91 s	11.72 s	35.15 s
10	3.52 s	10.55 s	31.64 s
11 <sup>1</sup>	3.20 s	9.59 s	28.76 s

<sup>1</sup> All binary inputs are stored as one channel.

Accuracy of the sampling value:

- measurement ranges 600 V, 100 V, 10 V, 1 V:  
± 0.2 % typical  
± 0.5 % guaranteed
- measurement range 100 mV:  
± 0.3 % typical  
± 0.6 % guaranteed

The accuracy data are full scale errors.

### 6.10.5 Trend Recording

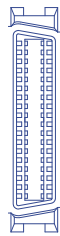
In Trend Recording Mode, you can make a historical plot of various measurements over time. It is possible to measure RMS voltage, RMS current, phase, active, apparent and reactive power and the power factor.

The main view has a CTS Chart. Each selected measurement function appears in a separate diagram (i.e. all frequency measurements in the frequency diagram). RMS current and voltage appear in separate diagrams. Time is displayed in seconds on the x-axis. The diagram is scrolled from right-to-left as new data is recorded.



## 6.11 The PAR-1 Option (CMC 256 with Parallel Port)

Figure 6-37:  
PC parallel printer port



The *CMC 256* requires the PAR-1 option (parallel printer port) to communicate with the *CMB IO-7* (refer to 9.3, "CMB IO-7" on page 115). When the OMICRON *Test Universe* software is started, it automatically searches for the parallel port (LPTx) of the PC to which the *CMC 256* is connected.

Please note that neither the LLO-2 ("LL out 7 - 12") option nor the *CMIRIG-B* can be used together with the PAR-1 option.

Figure 6-38:  
Rear view of the *CMC 256*  
with the PAR-1 option

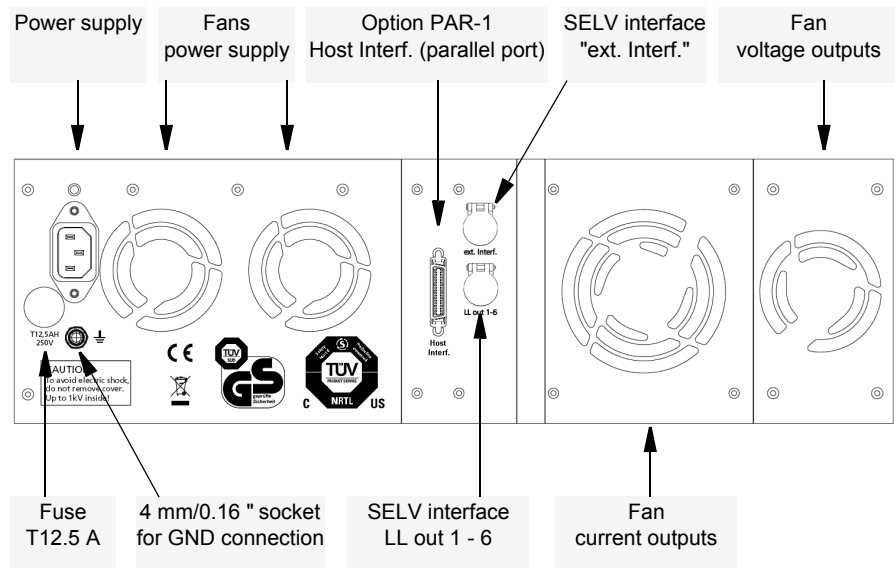
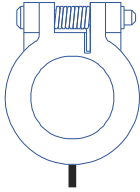


Table 6-51:  
Technical data of  
parallel port

Host Interface (parallel port)	
Connector / socket	IEEE 1284-C (parallel port)
Usage	The interface serves to connect the <i>CMC 256</i> with the computer. Note that the compliance with the requirements of electromagnetic compatibility (EMC) is guaranteed with the original manufacturer-supplied cables, only.
Insulation	Reinforced insulation to all other potential groups of the test equipment. GND is connected to protective earth (PE).

## 6.12 The LLO-2 Option (Low Level Outputs)



LL out 7 - 12

The LLO-2 option ("LL out 7 - 12") represents an additional SELV interface connector holding two independent generator triples (SELV = Safety Extra Low Voltage). These six high accuracy analog signal sources can serve to either control an external amplifier or to directly provide small signal outputs.

The outputs 7-12 extend the low level outputs 1-6 ("LL out 1-6") by two more independent generator triples. Outputs 7-12 are technically identical to outputs 1-6.

For more information please refer section 6.3.8, "Low Level Outputs "LL out" for External Amplifiers" on page 62.

## 7 INCREASING THE OUTPUT POWER

The *CMC 256* has a very large application diversity. The current outputs offer enough output power to test all electromechanical relays.

In particular, the *CMC 256* offers a variety of types of single-phase operation using its two galvanically separated current triples with which the output power from the units can be significantly increased.

In cases when the current or the output power – or even the number of independent voltages or currents – is insufficient, it is possible to connect individual amplifier groups of the *CMC 256* in parallel or to connect external amplifiers (up to six independent additional channels) to the "LL out 1-6".

The option "LLO-2" extends the low level outputs by two more independent generator triples "LL out 7-12" (refer to section Section 6.12 on page 98).



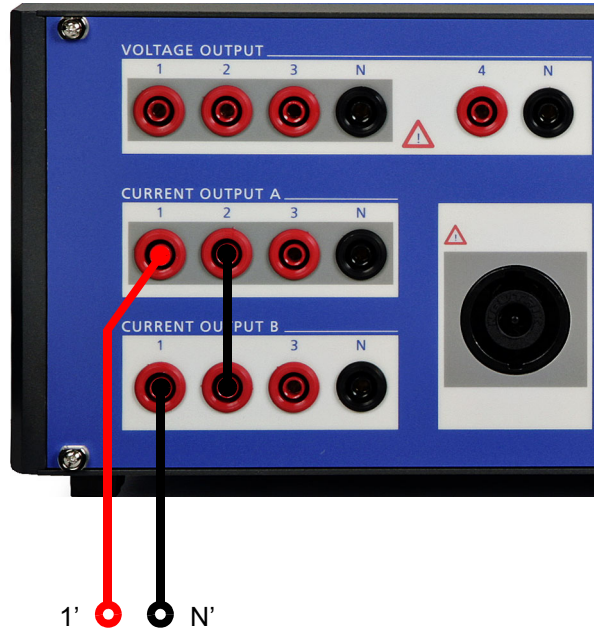
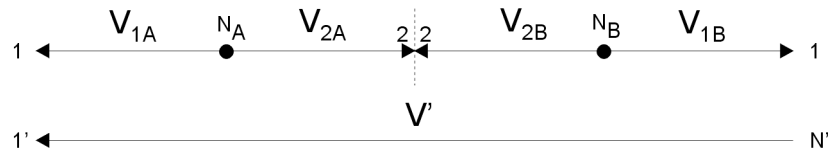
**Note:** The following output configuration examples represent a selection, only. For a complete list of possible configurations start the **Hardware Configuration** of the *OMICRON Test Universe* software and go to the **General** tab. At the **Test Set(s)** list box, select the proper CMC test set. Then click the **Details...** button to open the **Output Configuration Details** dialog box.

## 7.1 1 x 0 ... 12.5 A

Both amplifier groups CURRENT OUTPUT A and CURRENT OUTPUT B are connected in series. The currents 1 and 2 of a group are phase-opposite.

Typical: 1 x 0 ... 12.5 A; 320 VA at 8.5 A; max. 40 V<sub>rms</sub>.

Figure 7-1:  
CURRENT OUTPUT A and  
CURRENT OUTPUT B  
connected in series



Also refer to the output curves in section 6.3.4, "Single-phase Operation for Output Currents" on page 56.

## 7.2 1 x 0 ... 37.5 A

The individual currents outputs 1, 2, and 3 of the amplifier groups CURRENT OUTPUT A and CURRENT OUTPUT B are connected in parallel. The groups A and B are then connected in series.

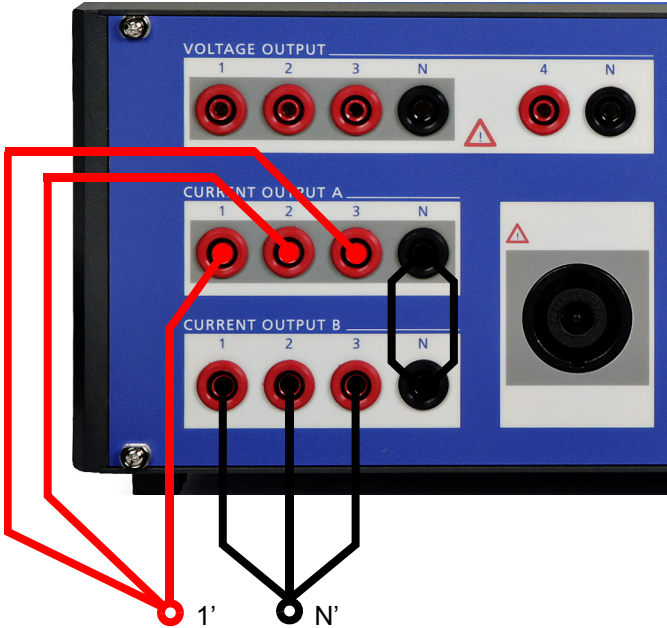
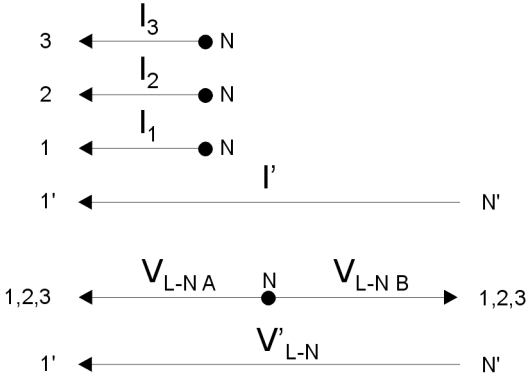
Typical: 1 x 0 ... 37.5 A; 480 VA at 25.5 A; max. 20 V<sub>rms</sub>.



**Note:** Verify a sufficient diameter of the test leads.

Every current socket can provide up to 12.5 A<sub>rms</sub>, and the N socket up to 3 x 12.5 A<sub>rms</sub> = 37.5 A<sub>rms</sub>.

Figure 7-2:  
Currents outputs 1, 2, and 3 of amplifier groups CURRENT OUTPUT A and CURRENT OUTPUT B connected in parallel; groups A and B then connected in series



Also refer to the output curves in section 6.3.4, "Single-phase Operation for Output Currents" on page 56.



**Note:**

- The phase angles of all outputs of the group A must be identical.
- The phase angles of all outputs of group B must be identical plus in phase opposition to the phase angle of group A.
- The amplitude of all outputs for both groups must be set to the same value.

Because test leads (2 m/6 ft. length, 2.5 mm<sup>2</sup>, 12.5 A) are subject to 2.5 W power loss, we recommend using the connection method as shown in figure 7-2, "Currents outputs 1, 2, and 3 of amplifier groups CURRENT OUTPUT A and CURRENT OUTPUT B connected in parallel; groups A and B then connected in series" on page 101.<sup>1</sup>

**WARNING:**



For currents greater than 25 A, the test object (load) should be exclusively connected to the 4 mm/0.16 " banana sockets and not on the generator connection socket.

<sup>1</sup> Double up the test leads for the N socket by using two test leads back to back. In addition ensure that the current outputs (1,2,3) are only connected together at the actual test object.

### 7.3 1 x 0 ... 75 A

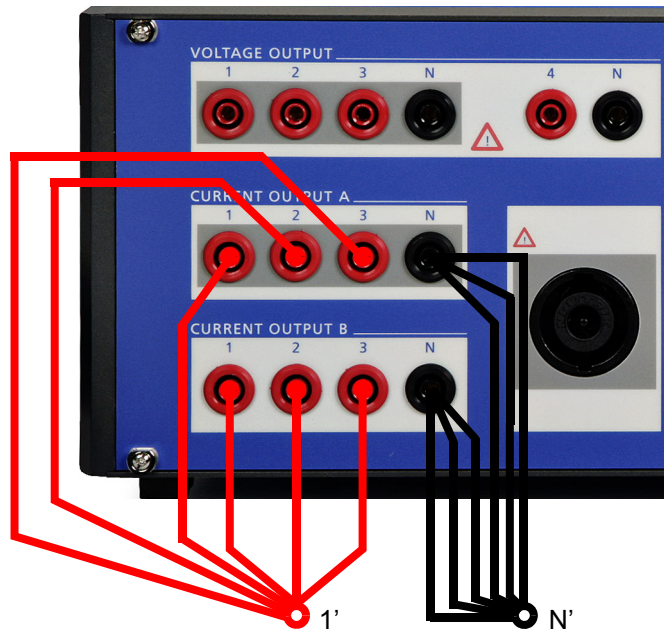
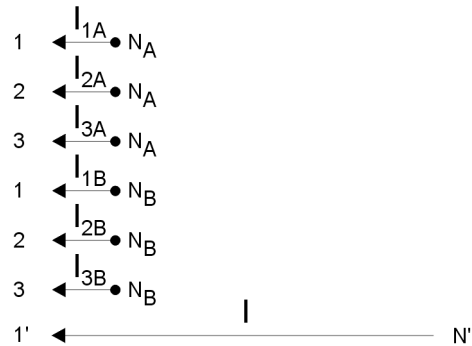
The individual currents outputs 1, 2, and 3 of the amplifier groups CURRENT OUTPUT A and CURRENT OUTPUT B are connected in parallel. The groups A and B are then connected in parallel, too.

Typical: 1 x 0 ... 75 A; 480 VA at 51 A; max. 10 V<sub>rms</sub>.

**Note:** Verify a sufficient diameter of the test leads.



Figure 7-3:  
Currents outputs 1, 2, and 3 of amplifier groups CURRENT OUTPUT A and CURRENT OUTPUT B connected in parallel; groups A and B then connected in parallel, too



Also refer to the output curves in SECTION 6.3.4, "Single-phase Operation for Output Currents" on page 56.

All six current channels have to be set to the same phase and the same amplitude.

Because test leads (2 m/6 ft. length, 2.5 mm<sup>2</sup>, 12.5 A) are subject up to 2.5 W power loss, we recommend using the connection techniques from figure 7-3, "Currents outputs 1, 2, and 3 of amplifier groups CURRENT OUTPUT A and CURRENT OUTPUT B connected in parallel; groups A and B then connected in parallel, too" on page 103.<sup>1</sup>

**WARNING:**

For currents greater than 25 A, the test object (load) should be exclusively connected to the 4 mm/0.16 " banana sockets and not on the generator connection socket.

<sup>1</sup> Triple up the test leads for the N socket by using three test leads back to back. In addition ensure that the current outputs (1,2,3) are only connected together at the actual test object.

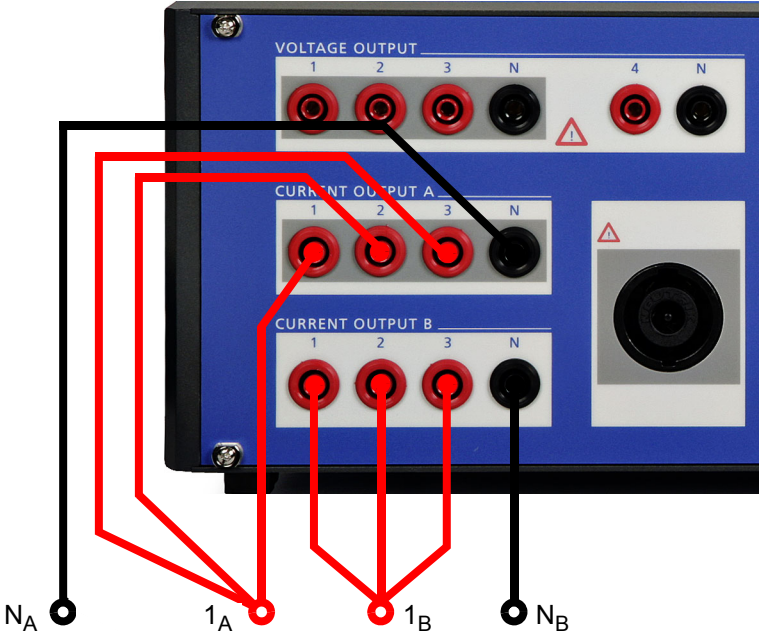


### 7.4 2 x 0 ... 37.5 A

The individual currents outputs 1, 2, and 3 of the amplifier groups CURRENT OUTPUT A and CURRENT OUTPUT B are connected in parallel. The groups A and B are used individually.

2 x 37.5 A; 210 VA at 22.5 A; 10 V<sub>rms</sub>

Figure 7-4:  
Currents outputs 1, 2, and 3 of amplifier groups CURRENT OUTPUT A and CURRENT OUTPUT B connected in parallel; groups A and B are used individually

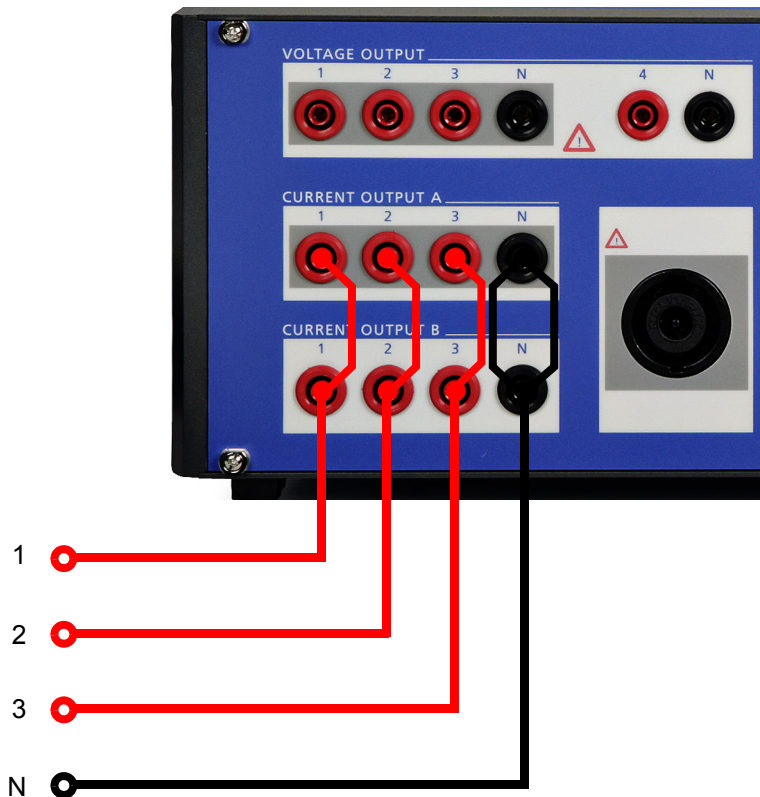


## 7.5 3 x 0 ... 25 A

The individual current outputs 1, 2, and 3 of the amplifier group CURRENT OUTPUT A are connected to the equivalent outputs of the amplifier group CURRENT OUTPUT B.

3 x 0 ... 25 A; 140 VA at 15 A; max. 10 V<sub>rms</sub>.

Figure 7-5:  
Current outputs 1, 2, and 3  
of amplifier group  
CURRENT OUTPUT A  
connected to equivalent  
outputs of amplifier group  
CURRENT OUTPUT B



### 7.6 Single-Phase Voltage

Figure 7-6:  
Single-phase operation of  
the voltage system (L-N)

1 x 0 ... 300 V.  
Typical 200 VA at  
100 ... 300 V.

See also figure 6-14,  
"Single-phase  
operation L-N" on  
page 60.

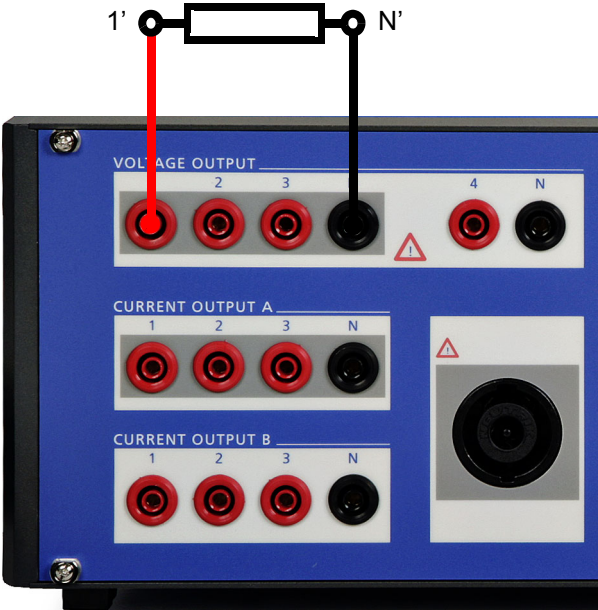
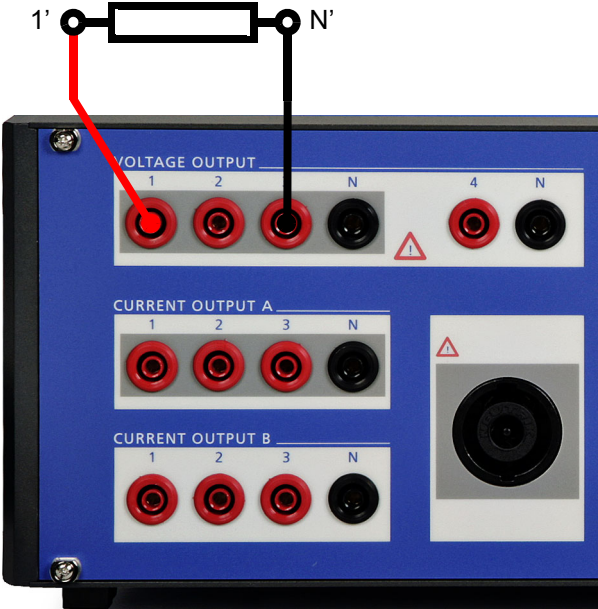


Figure 7-7:  
Single-phase operation of  
the voltage system  
(L-L phase opposition)

1 x 0 ... 600 V  
Typical 275 VA at  
200 ... 600 V.

See also figure 6-15,  
"Single-phase  
operation L-L" on  
page 60.



Also refer to section 6.3.5, "Voltage Outputs" on page 58.

## 7.7 Operation with External Amplifiers

The connections "LL out 1-6" offers a large variety of extension possibilities through the connection of external amplifiers.

As such, higher currents and higher power outputs can be generated, or the number of independent voltage or current channels can be extended.

Applications which the *CMC 256* alone cannot cover, thus become realizable.

Each LL output socket ("LL out 1-6" and the optional "LL out 7-12") can connect up to four external amplifiers with six independent channels.

The following configurations are possible:

- $9 \times 25 \text{ A}_{\text{rms}} / 70 \text{ VA}$  for differential relays in three galvanically separated current triples with *CMC 256 + CMA 156*.
- $6 \times 250 \text{ V} / 75 \text{ VA}$  for the synchronization in two galvanically separated voltage triples with *CMC 256 + CMS 156*.

For a complete overview of the supported configurations of the *CMC 256* and *CMA/S* amplifiers see the *OMICRON Test Universe* Help, topic **Hardware Configuration**.

## 8 TROUBLESHOOTING

### 8.1 Troubleshooting Guide

In case of operational problems with the *CMC 256* proceed as follows:

1. Consult the reference manual or the OMICRON *Test Universe* Help.
2. Check whether the malfunction is reproducible and document it.
3. Try to isolate the malfunction by using another computer, test set or connecting cable, if available.
4. Note the exact wording of any error message or unexpected conditions.
5. If you contact the OMICRON technical support, please attach:
  - your company name as well as a phone number and e-mail address
  - the serial number of your test set
  - information about your computer: Manufacturer, type, memory, installed printers, operating system (and language) and the installed version and language of the OMICRON *Test Universe* software.
  - screenshots or the exact wording of possible error messages.
6. If you call the OMICRON hotline, please have your computer and test set available and be prepared to repeat the steps that caused the problem.

To speed up the support, please attach the following diagnostic log files:

- **Communication log file**

This file records any communication between the CMC 256 and the computer. To send the log file to the OMICRON technical support:

1. Close all other applications.
2. From the *Test Universe* Start Page, select **Calibration & Diagnosis...** and then **Logfile**.
3. Select **Logging on (Detailed)** in the **Edit** menu and minimize the window.
4. Start the test module and reproduce the malfunction.
5. Go back to the log file and select **Send** in the **File** menu to submit the log file via e-mail to the OMICRON technical support.

- **Hardware check log file**

Each time a test module starts, an internal hardware self-check is performed. The results of this test are stored in the hwcheck.log file.

To open the log file, select **Calibration & Diagnosis...** and then **Hardware Check** from the *Test Universe* Start Page.

## 8.2 Potential Errors, Possible Causes, Remedies

Some potential disruptions that may occur while operating the *CMC 256* are listed below. Try to eliminate them by applying the remedies proposed here.

Table 8-1:  
Troubleshooting the  
*CMC 256*

Error	Possible causes	Remedies
Power switch does not light up after turning on the <i>CMC 256</i> test set.	<p>There is no power to the test set.</p> <p>The fuse of the test set is blown</p> <p>Malfunction of internal test set components</p>	<p>Check the power supply and assure that it supplies power to the test set.</p> <p>Unplug the power cord from the power source! Replace the fuse: T 12 AH 250 V (5 x 20 mm).</p> <p>Please contact the OMICRON technical support (refer to section "Contact Information / Technical Support" on page 149).</p>
<p>The following message appears in the status line: "WARNING: Broken ground connection! Immediately turn off the test set! Resuming the operation can result in hazard to life and is done at your own risk."</p>	<p>Ground-wire connection to the <i>CMC 256</i> is broken or the test set is powered by an earth-free power supply.</p> <p><b>Note:</b> Never connect the <i>CMC 256</i> to an isolating transformer.</p>	<p>Check the ground connection.</p> <p>Ground the housing of the test set separately using the PE connection socket (on the back panel of the test set).</p>

## 8.3 Overheating

If a thermal shutdown occurs because of loading the voltage or current outputs a long time by high burden, the *Test Universe* displays the following messages respectively in the Status History window:

- **“Voltage overtemperature:” followed by a list of the affected outputs**  
“CMC switched off.”  
“Test stopped with error.”
- **“Current overtemperature:” followed by a list of the affected outputs**  
“CMC switched off.”  
“Test stopped with error.”

The thermal shutdown can be avoided by reducing the compliance voltage of the current amplifiers, i.e., to optimize the output power limit of the current outputs set the compliance voltage of the internal current amplifiers.

To do so, go to the **Compliance Voltage** group box of the **Output Configuration Details** dialog box in the *Test Universe Hardware Configuration*.

By reducing the power supply voltage, the ON-time can be prolonged considerably for low-ohmic burdens, because this causes the internal amplifier to consume less power. Hence, the internal heat dissipation can be reduced, especially when testing with low burden test objects. This then considerably extends the time until the device switches OFF due to thermal overload.



For more detailed information refer to the *Test Universe* Help. Select the **Hardware Configuration** Help and navigate to the topic **Setting the Current Output Power Limit of CMC Test Sets**.





## 9 CMC 256-RELATED PRODUCTS AND ACCESSORIES

This chapter describes the optional equipment for the *CMC 256* test set. In the following the amplifiers *CMA 56*, *CMA 156*, *CMS 156*, *CMS 251* and *CMS 252* are jointly named CMA/S. Please visit the OMICRON Web site [www.omicron.at](http://www.omicron.at) for up-to-date information.

### 9.1 CMA Current Amplifiers & CMS Voltage Amplifiers

The CMA/CMS external amplifiers are controlled by the *CMC 256* test set via the “LL out 1-6” on the rear panel of the test set as shown in figure 9-1 below. The option "LLO-2" extends the low level outputs by two more independent generator triples “LL out 7-12” (refer to section 6.12 on page 98).

Figure 9-1:  
Connecting a CMA/S  
amplifier to the *CMC 256*

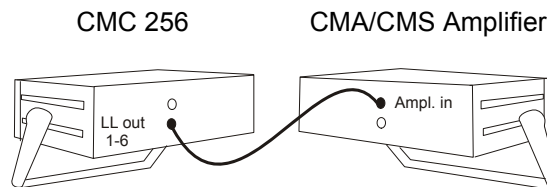


Table 9-1:  
Technical data of CMA/S  
amplifiers

Amplifier	Output configurations	Output power	Miscellaneous
<i>CMA 156</i>	6-phase current amplifier (Group A, B) 6 × 25 A (L-N) 3 × 50 A (L-N) 2 × 75 A (3L-N) 1 × 150 A (3L-N)	6 × 70 VA at 7.5 A 3 × 140 VA at 15 A 2 × 225 VA at 22.5 A 1 × 420 VA at 45 A	Amplitude accuracy: error < 0.1 %. Weight: 15.4 kg (34 lbs)
<i>CMS 156</i>	3-phase current/voltage amplifier 3 × 250 V (L-N) 1 × 500 V (L-L) 3 × 25 A (L-N) 1 × 75 A (3L-N)	3 × 75 VA 1 × 150 VA 3 × 70 VA at 7.5 A 1 × 210 VA at 22.5 A	Amplitude accuracy: error < 0.1 %. Weight: 14.7 kg (32.4 lbs)

Detailed information about the CMA/S amplifiers can be found in the corresponding user manuals, the product catalog, or on the OMICRON Web site [www.omicron.at](http://www.omicron.at).

For ordering information about the individual OMICRON amplifiers, please refer to table 9-5, "Order numbers overview" on page 139.

## 9.2 CMControl-6

Figure 9-2:  
CMControl-6 attached to a  
CMC 256plus test set



### Order numbers:

**VEHO2806 (CMControl-6); upgrade for an existing CMC 256**

**VEHO2805 (CMControl-6); add-on for new CMC 256**

The *CMControl* is a front panel control device for CMC test sets. Its instant availability and its easy operation concept make it the ideal solution for the quick verification of test objects.

The *CMControl* provides an intuitive touch screen user interface that makes setting up tests particularly easy and convenient. The control wheel allows quick and accurate adjustment of the output quantities. The included test tools and integrated fault models cover almost all common test tasks and support the tester in getting reliable results quickly.

The *CMControl* can either be used attached to the CMC test set as front panel control or detached as a handheld control device. Its magnetic rear allows easy attachment to standard racks while its built-in stand works perfectly on every table.

The *CMControl* is available in two variations: CMControl-6 for *CMC 356*, *CMC 256plus* and *CMC 256-6*, and CMControl-3 for *CMC 353*.

The rugged Ethernet connector ensures reliable communication with the CMC test set. The *CMControl* is designed to optimally meet the requirements for commissioning and maintenance of protection devices and substations.

For ordering information about the *CMControl*, refer to table 9-5, "Order numbers overview" on page 139.

## 9.3 CMB IO-7

The *CMB IO-7* is a computer-controlled extension unit used for applications where the number of available binary inputs and outputs of a CMC test set is not sufficient. The binary inputs and outputs of *CMB IO-7* can be used as an equivalent extension.

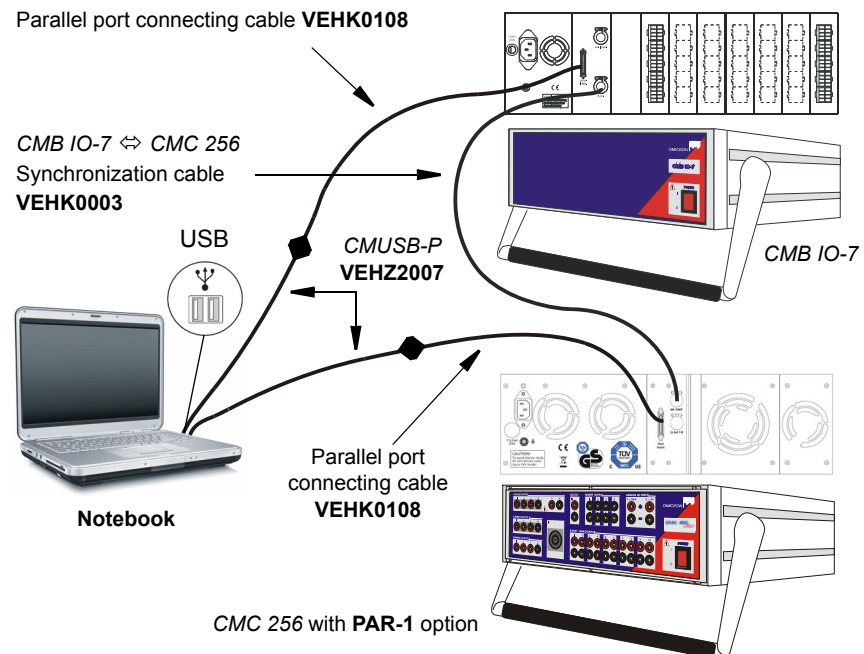
*CMB IO-7* provides seven module plug-in slots that can be equipped with different input/output modules. Depending on the modules, the *CMB IO-7* is capable of providing up to 144 potential-sensing (wet) or potential-free (dry) 300 VDC input channels and/or up to 96 output channels.

The signals applied to the inputs of the *CMB IO-7* are precisely time-tagged. With the OMICRON *Test Universe* software, you can define a timing characteristic for the output reactions by using freely programmable sequences.

The following IO modules are available:

- INP1-24: 24 binary inputs, 0 ...300 VDC, two galvanically separated groups 12 + 12
- OUT1-16: 16 binary relay outputs
- OUT2-16: 16 binary solid-state outputs, high-side MOSFET outputs (fast, no bouncing).

Figure 9-3:  
Typical test setup with  
*CMB IO-7*,  
*CMC 256 PAR-1*,  
*CMUSB-P* and a notebook  
with USB ports



The *CMB IO-7* can be used either stand-alone or together with the *CMC 256* test set.

The *CMC 256* requires the PAR-1 parallel port option to communicate with the *CMB IO-7*.

If the computer controlling the *CMC 256* and the *CMB IO-7* is equipped with USB ports, two *CMUSB-P* converters are joined up in circuit between the parallel port connecting cables VEHK0108 and the computer's USB ports (see figure 9-3).

If the computer controlling the *CMC 256* and the *CMB IO-7* is not equipped with USB ports but a model with a parallel port, it needs to be upgraded with a second parallel port in order to communicate with the "Host Interfaces" of both *CMC 256* and *CMB IO-7*. To upgrade your computer with a second parallel port, both an express card type SPPXP-100 and a SPP-100 PCMCIA card with parallel port are available from OMICRON.

For ordering information about the *CMB IO-7*, please refer to table 9-5, "Order numbers overview" on page 139.

## 9.4 CMUSB-P Converter

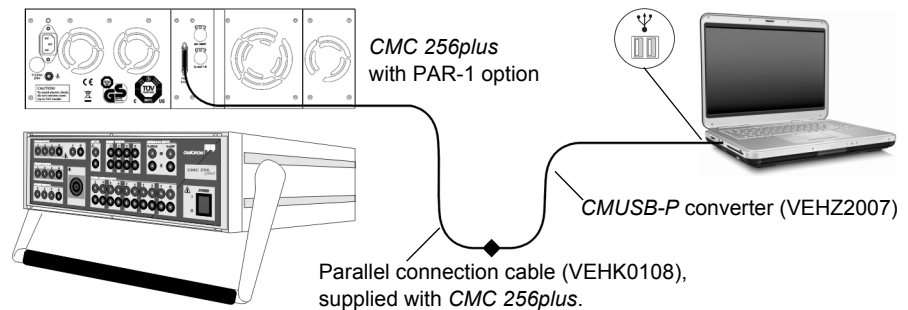
The *CMUSB-P* is a converter for controlling CMC test sets equipped with parallel ports such as *CMC 156*, *CMC 256* or *CMC 256plus* with PAR-1 option by computers with USB port.

Furthermore, the *CMB IO-7* (binary inputs/outputs extension unit) is supported. The *CMUSB-P* is designed to convert the USB signals of the computer to the communication protocol used by the OMICRON devices.

Figure 9-4:  
*CMUSB-P* converter



Figure 9-5:  
Connecting a  
*CMC 256plus* with PAR-1  
option to a computer's  
USB port

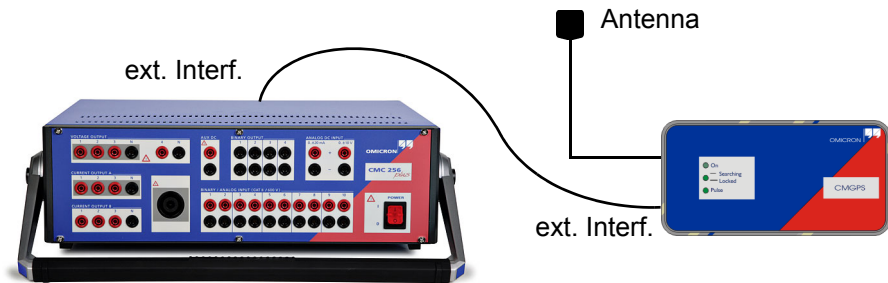


## 9.5 Time Synchronization Accessories

### 9.5.1 CMGPS

You can synchronize two or more CMC test sets by connecting a *CMGPS* synchronization unit to each of the test sets' "ext. Interf." inputs. Since the GPS (Global Positioning System) signal is available worldwide, the physical distance between these test sets is thereby of no relevance ("end to end" testing).

Figure 9-6:  
CMGPS synchronization unit



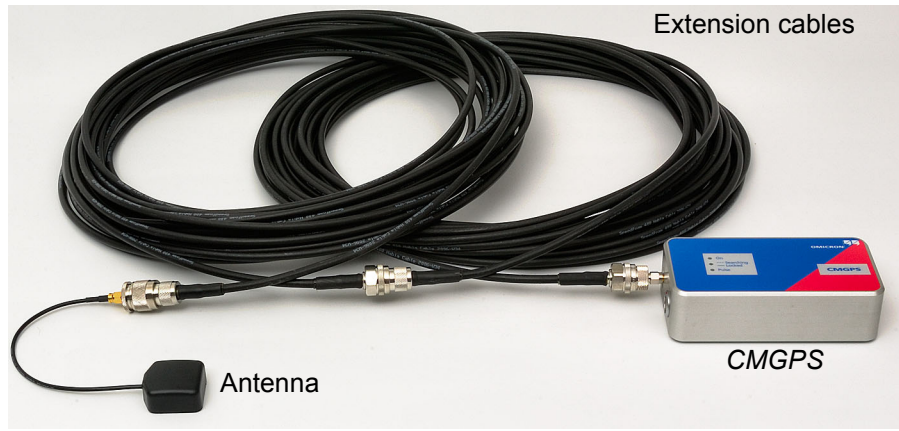
For detailed information about the *CMGPS*, please refer to the *CMGPS* reference manual, the product catalog, or the OMICRON Web site [www.omicron.at](http://www.omicron.at). For ordering information about the *CMGPS*, refer to table 9-5, "Order numbers overview" on page 139.

Table 9-2:  
Basic technical data of the  
*CMGPS* synchronization unit

Pulse outputs	2
Accuracy	Error < $\pm 1 \mu\text{s}$ or $\pm 5 \mu\text{s}$
Synchronization of test sets <sup>1</sup>	Error < $100 \mu\text{s}$ / < $5 \mu\text{s}$ (voltage amplifier) Error < $100 \mu\text{s}$ / < $20 \mu\text{s}$ (current amplifier)
Connection	Voltage supply from the <i>CMC 256</i> test set. Configured by the <i>Test Universe</i> software.
Weight	440 g (1 lbs)
Dimensions W x H x D	140 x 70 x 40 mm (5.5 x 2.8 x 1.6 ")

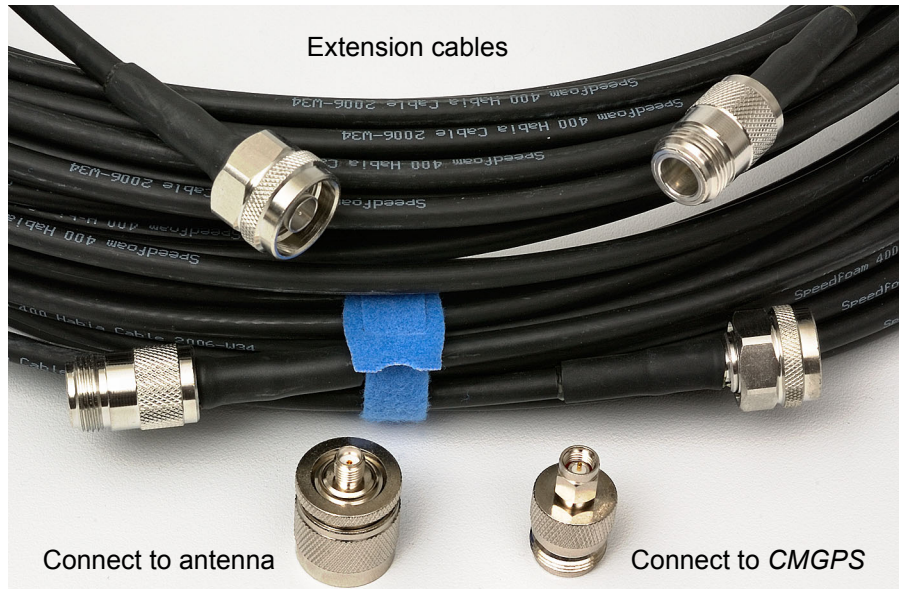
<sup>1</sup> Error corresponds to amplifier output signals (voltage/current) of *CMGPS*-synchronized test sets at configured GPS trigger event  
 $5 \mu\text{s}$  /  $20 \mu\text{s}$ : enhanced mode only in supported *Test Universe* test modules (refer to *Test Universe* Help, topic "Time Trigger Configuration").

Figure 9-7:  
CMGPS connected to antenna via 2 × 20 m extension cables



For cases that may require an extension of the antenna cable, an optional set of 2 × 20 m cables is available from OMICRON. For ordering information, refer to table 9-5, "Order numbers overview" on page 139.

Figure 9-8:  
Adapter to connect the extension cables to CMGPS and antenna

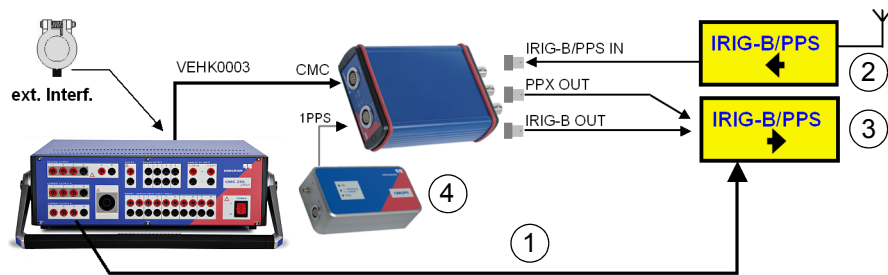


## 9.5.2 CMIRIG-B

Via the *CMIRIG-B* interface box you can connect devices to the *CMC 256* test set that either transmit or receive the IRIG-B time reference signal (DC level shift protocol B00x). That way, two or more *CMC* test sets are synchronized. Furthermore, an optional *CMGPS* synchronization unit can be integrated into the test setup to serve as source of the synchronization moment or 1PPS signal, respectively. *CMC 256* decodes (when receiving) or encodes (when transmitting) the IRIG-B protocol. The IRIG-B protocol extensions required by standard IEEE C37.118 are supported as well.

The most significant functional enhancement of those *Test Universe* test modules supporting the IRIG-B time reference is the starting and synchronizing of *CMC 256* states (signal output) with high accuracy synchronous to the IRIG-B<sup>1</sup> time reference or PPS/PPX<sup>2</sup> signal, respectively; for example for PMU synchrophasor tests.

Figure 9-9:  
Typical test setup with  
*CMIRIG-B*  
(not true to scale)



- ① Test signals (e.g., 3 x current, 3 x voltage).
- ② IRIG-B/PPS source, e.g. GPS receiver with IRIG-B output.
- ③ IRIG-B/PPS receiver, e.g. protection relay, PMU.
- ④ Optional *CMGPS* synchronization unit (depends on the application).

### Requirements:

- *CMC 256* standard test set with Ethernet ports; **not** with PAR-1 option).
- IRIG-B source or receiver with 5 V/TTL level; demodulated; DC level shift protocol (B00x).

<sup>1</sup> IRIG stands for Inter Range Instrumentation Group and represents a serial time code format.

<sup>2</sup> PPS: pulses per second

PPX: programmable PPS signal (pulse rate, e.g., 1 pulse per minute or one pulse per 10 seconds)



### CMIRIG-B timing specifications

Figure 9-10:  
CMIRIG-B timing in detail

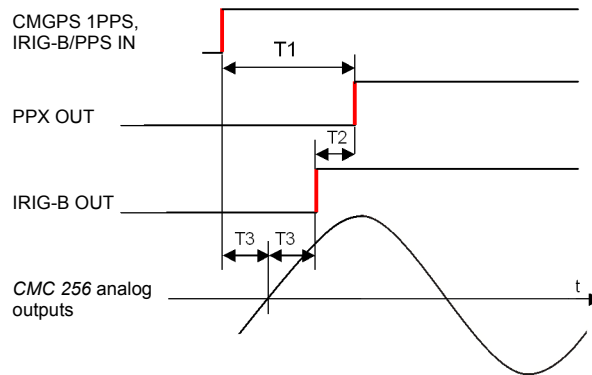


Table 9-3:  
Timing specifications

Timing specifications	
T1 (delay time PPS source to PPX OUT)	< 1 $\mu$ s typ., 1.5 $\mu$ s max.
T2 (time skew PPX OUT to IRIG-B OUT)	< $\pm$ 0.1 $\mu$ s typ., $\pm$ 0.5 $\mu$ s max.
T3 (time error of time reference source to analog outputs) <sup>1</sup>	
- Current outputs	$\pm$ 1 $\mu$ s typ., $\pm$ 5 $\mu$ s guar.
- Voltage outputs	$\pm$ 1 $\mu$ s typ., $\pm$ 5 $\mu$ s guar.

<sup>1</sup> Valid for CMC 256plus output frequencies < 100Hz and re-synchronized analog output signals.

For ordering information, refer to table 9-5, "Order numbers overview" on page 139.



For detailed information about the OMICRON CMIRIG-B interface box please refer to the CMIRIG-B Reference Manual.



Detailed information about the IRIG-B standard can be found, for example, in the IRIG SERIAL TIME CODE FORMATS publication at the url <https://wsmrc2vger.wsmr.army.mil/rcc/manuals/200-04/index.html>.



Detailed information about how to configure the *Test Universe* software component **Time Trigger Configuration** for the use of CMIRIG-B with or without CMGPS can be found in the CMIRIG-B Reference Manual and in the *Test Universe* Help, topics **Time Trigger Configuration** and **Hardware Configuration (IRIG-B & GPS tab)**.

## 9.6 100TX to 100FX-SC Converter

Figure 9-11:  
100TX to 100FX-SC  
Converter



**Order number: VEHZ0021**

This converter connects the *CMC 256* to a network via fiber optics.

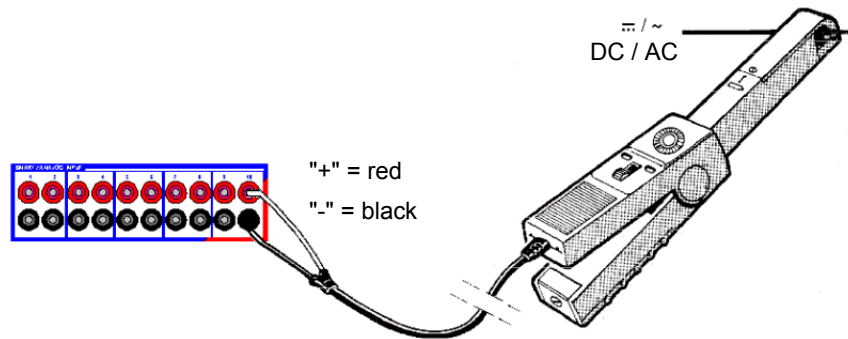
The *100TX to 100FX-SC Converter* transfers data from a 10/100Base-TX copper to a fiber interface. It is designed to receive both data and power from PoE networks, and to pass on the data to a fiber optics connection.

## 9.7 Current Clamp C-PROBE1

Using the current clamp *C-PROBE1* and the *EnerLyzer* measurement option, direct and alternating currents can be measured via the analog measurement inputs of the BINARY / ANALOG INPUT section (refer to section 6.10, "The EnerLyzer Measurement Option" on page 78).

*C-PROBE1* is an active, DC-capable current probe and has two switchable measurement ranges.

Figure 9-12:  
Current clamp *C-PROBE 1*



For detailed information about the *C-PROBE1* current clamp and the *EnerLyzer* measurement option, please refer to the respective reference manuals, the product catalog, or visit the OMICRON Web site [www.omicron.at](http://www.omicron.at).

Table 9-4:  
Basic technical data of  
*C-PROBE 1*

Max. voltage of the leads	600 V <sub>rms</sub> to GND	
Switch position	100 mV/A	10 mV/A
Measurement ranges	0...10 A AC/DC	0...80 A AC/DC
Frequency bandwidth	0 (DC)...10 kHz	

For ordering information about the *C-PROBE-1*, please refer to table 9-5, "Order numbers overview" on page 139.

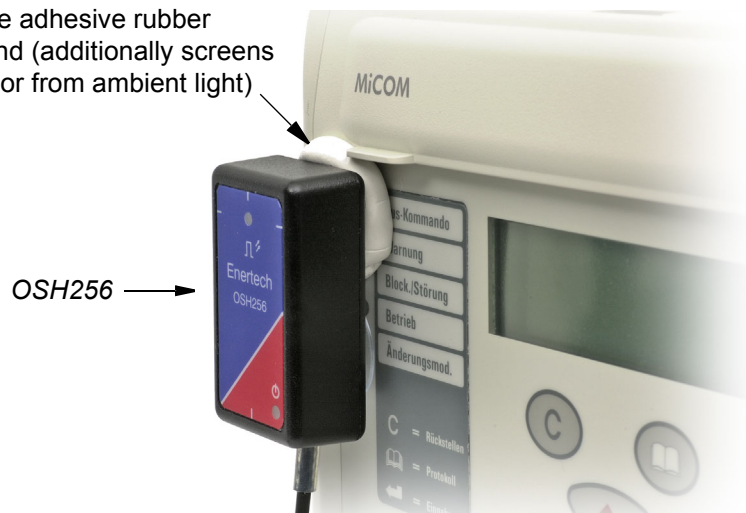
## 9.8 Accessories for Meter Testing

### 9.8.1 Scanning Head OSH256

The passive optical scanning head *OSH256* detects the status of an LED, that is either an optical pulse output from an energy meter or the binary status of a protective relay or other similar optical source.

Figure 9-13:  
The optical scanning head *OSH256* attached to an energy meter by rubber adhesive

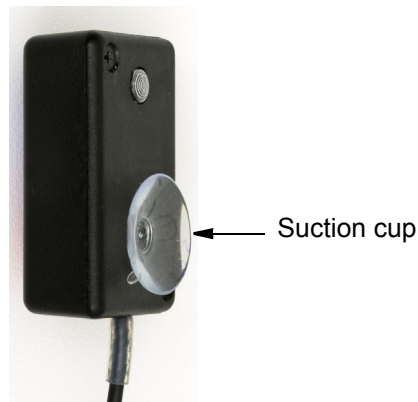
Reusable adhesive rubber compound (additionally screens the sensor from ambient light)



Order number: **VEHZ2006**

The *OSH256* has a unique fixing method as the lightweight unit can be attached to smooth surfaces by means of its suction cup (figure below) or by a re-usable adhesive rubber compound in case of a non-planar surface (figure above).

Figure 9-14:  
Suction cup of the optical scanning head *OSH256*



The *OSH256* connects to the EXIF socket of a *CMC 256* by means of the adapter cable *VEHK0010* (refer to section 9.8.5, "Adapter Cable for Scanning Heads" on page 128) or a *CMLIB B* (refer to section 9.8.6, "CMLIB B" on page 129).

For relay testing applications the *IFB256* serves to connect to a binary input of a *CMC* test set (refer to section 9.8.2 below).

### 9.8.2 Interface Box IFB256

Typically, the combination of a scanning head *OSH256* with an interface box *IFB256* is used for relay testing when binary information (a trigger signal) originates from a relay's LED. The *IFB256* is directly connected to the EXIF socket of a *CMC 256*, which provides the auxiliary DC supply through the *IFB256* to the scanning head. The binary signal is connected to the inputs of the *CMC* via banana plug leads.

Figure 9-15:  
Interface box *IFB256*



**Order number: VEHZ1152**

### 9.8.3 Scanning Head TK 326

The photoelectric scanning head *TK 326* is suitable for scanning of all known rotor marks of Ferraris meters and for scanning of LEDs up to the infrared wavelength range. It includes a spiral cable for the connection to the adapter cable or to a *CMLIB B*.

Figure 9-16:  
The photoelectric scanning  
head *TK 326*



**Order number: VEHZ2008**

The *TK 326* connects to the EXIF socket of a *CMC 256* by means of the adapter cable *VEHK0010* (refer to section 9.8.5, "Adapter Cable for Scanning Heads" on page 128) or a *CMLIB B* (refer to section 9.8.6, "CMLIB B" on page 129).

#### 9.8.4 Scanning Head TVS 6.15/1

The magnetic scanning head **TVS 6.15/1** (dia. 32 mm/1.3") is available for electronic meters with optical pulse outputs and matching mechanical interface.

Figure 9-17:  
The magnetic scanning  
head *TVS 6.15/1*



**Order number: VEHZ2004**

The *TVS 6.15/1* connects to the EXIF socket of a *CMC 256* by means of the adapter cable *VEHK0010* (section 9.8.5 on page 128) or a *CMLIB B* (section 9.8.6 on page 129).

### 9.8.5 Adapter Cable for Scanning Heads

The adapter cable VEHK0010 connects the scanning heads *OSH256*, *TK 326* and *TVS 6.15/1* directly to a *CMC 256* test set. The scanning heads connection cable is simply extended by the adapter cable plugging the 5-pole LEMO connectors into each other. The 16-pole LEMO connector is plugged into the LEMO socket "ext. Interf." at the rear of a CMC test set. From there the scanning heads are supplied with 14 VDC and meter pulses are fed to the counter input of the CMC.

Figure 9-18:  
Connecting an optical scanning head to the CMC 256 "ext. Interf." connector

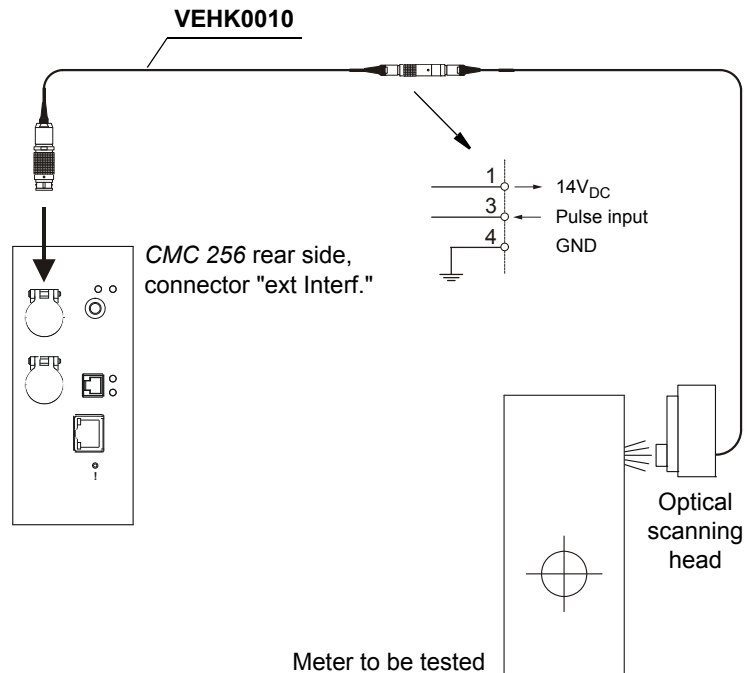


Figure 9-19:  
Adapter cable for scanning heads



For ordering information about scanning heads, please refer to table 9-5, "Order numbers overview" on page 139.



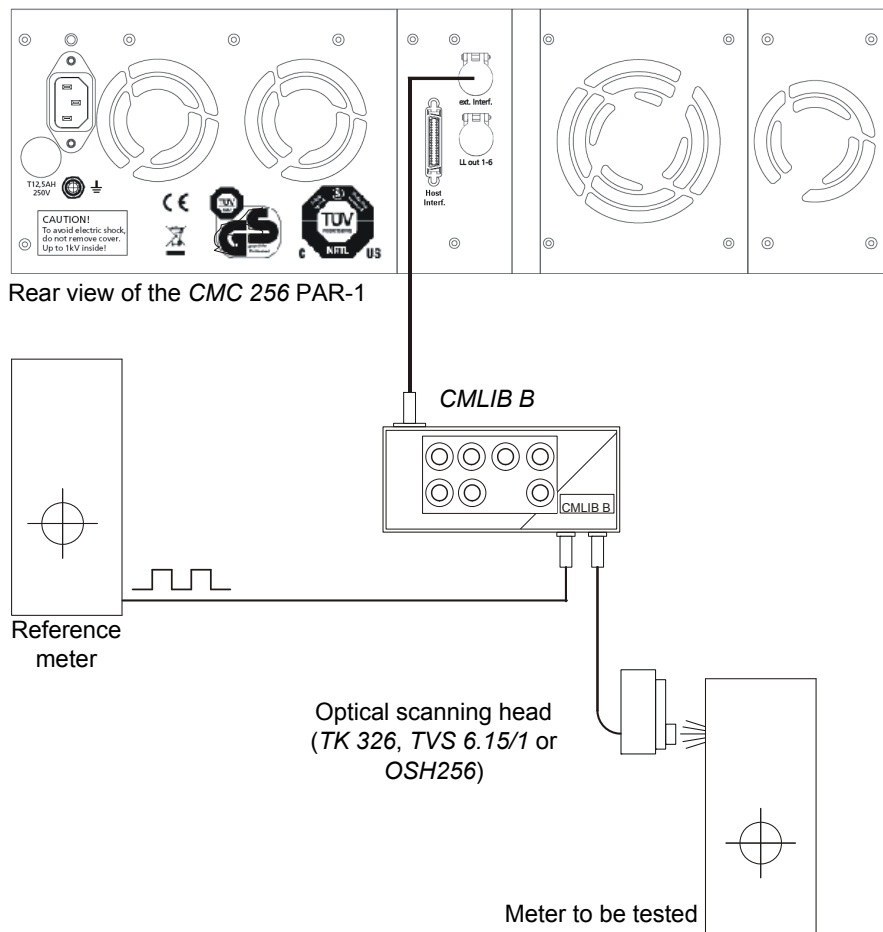
### 9.8.6 CMLIB B

There are some meter testing applications where the simple adapter cable (section 9.8.5) does not prove sufficient for the test setup:

- if a reference meter is used and therefore two pulse inputs are required
- if the binary transistor outputs of a *CMC 256* test set need to be accessed.

For these applications, the *CMLIB B* is used as interface.

Figure 9-20:  
Connecting a *CMLIB B*  
(not true to scale)



For detailed information about the *CMLIB B*, please refer to the *CMLIB B* reference manual, the product catalog, or visit the OMICRON Web site [www.omicron.at](http://www.omicron.at). For ordering information about the *CMLIB B*, please refer to table 9-5, "Order numbers overview" on page 139.

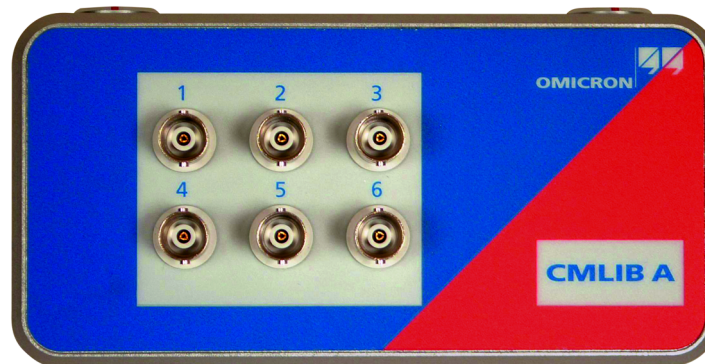
### 9.8.7 CMLIB A

*CMLIB A* is connected between a CMC test set and an amplifier to tap the analog low level signal outputs. Furthermore, *CMLIB A* can be connected to the analog control inputs of the optional amplifiers *CMA 156* and *CMS 156*.

Applications for *CMLIB A*:

- Connection of amplifiers that do not have an OMICRON connection socket to the CMC analog low level signal outputs.
- Connection of OMICRON amplifiers to controlling sources that do not have an OMICRON connection socket.
- Convenient tapping of the signals between the CMC test set and OMICRON amplifiers.

Figure 9-21:  
*CMLIB A*



**Order number: VEHZ1101**

The *CMLIB A* set (**VEHZ1105**) includes the *CMLIB A* interface box (**VEHZ1101**) as shown above in figure 9-21, and the 16-pole LEMO cable (**VEHK0003**) to connect the interface box to either a CMC test set or an OMICRON amplifier.

### CMLIB A accessory cables

Figure 9-22:  
CMLIB A accessory cables



BNC to BNC  
Order number: **VEHK0008**



BNC to 4 mm banana  
Order number: **VEHK0005**

The *CMLIB A* accessory cables are to be ordered separately. Each order number represents one piece of cable.

### 9.8.8 CPOL Polarity Tester



The portable and easy-to-use *CPOL* Polarity Tester is designated to check a series of test points for correct polarity as a substitute for the battery checking method.

The *CMC 256* injects a special continuous voltage or current test signal at one point. Then *CPOL* checks the polarity at all terminals and provides a clear indication as to whether the polarity is OK (green LED) or not (red LED). This procedure is much faster than the conventional method and can easily be performed by a single person.

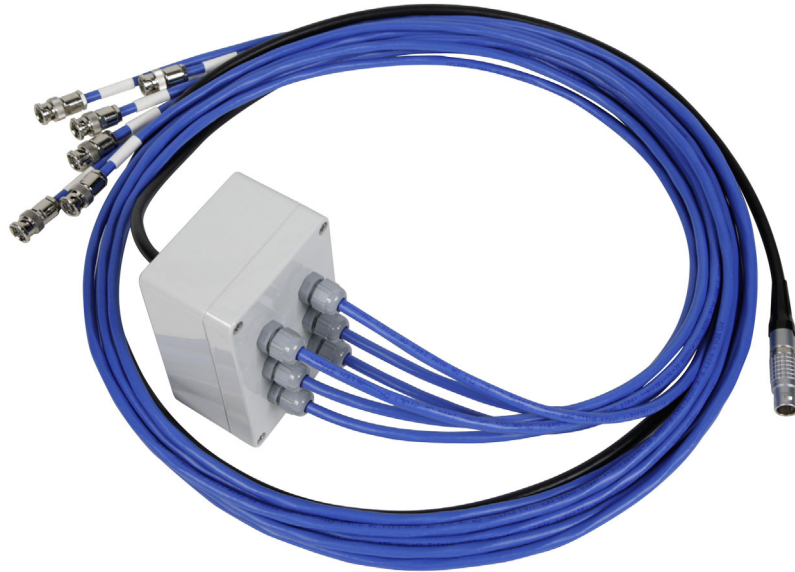
*CPOL* is used in conjunction with the *Polarity Checker* test tool that is part of the *Test Universe* software.

Order number: **VEHZ0645**

### 9.8.9 Connection Cable for REF 54x Relays (ABB) with Low Level Signal Inputs

This connection cable with twin-BNC clamp plugs type AMPHENOL 31-224 is tailored to connect ABB relays of the REF 54x series (with AMPHENOL twin-BNC bulkhead receptacles type 31-223) to the low level outputs of the CMC 256 (16-pole LEMO connector).

Figure 9-23:  
REF 54x cable connector



**Order number: VEHK0120**

Cable length: approx. 2.5 m (8.2 feet).

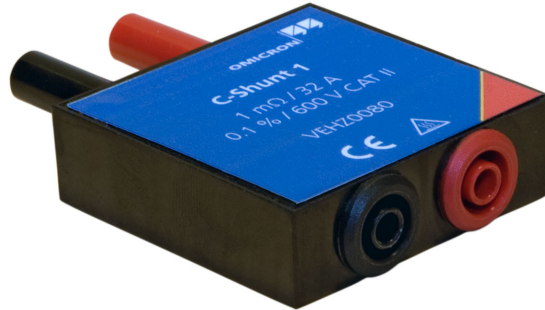
The six cable tails with the AMP connectors are labeled.

The CMC test set in such applications simulates unconventional transformers and/or Rogowski coils.

### 9.8.10 C-Shunt

*C-Shunt 1* and *C-Shunt 10* are precision shunts for current measurements. They can be directly inserted into the binary/analog inputs of a *CMC 256*.

Figure 9-24:  
*C-Shunt 1*



**Order numbers:**

**C-Shunt 1: VEHZ0080**

**C-Shunt 10: VEHZ0081**

<b>C-Shunt 1</b>	
Electrical resistance	0.001 $\Omega$
Resistance Tolerance	0.1 %
Temperature coefficient	$\geq 30$ ppm/K in the range 0 ... +70 °C (32 ... +158 °F); according to IEC 60115-1 4.8
Maximum current	32 A continuous
Insulation class	600 V CAT II

*C-Shunt 10* is a 10 m $\Omega$  precision shunt for current measurements. It can be directly inserted into the test set's binary/analog inputs.

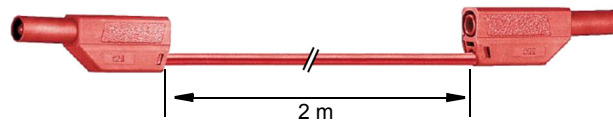
<b>C-Shunt 10</b>	
Electrical resistance	0.01 $\Omega$
Resistance Tolerance	0.1 %
Temperature coefficient	$\geq 18$ ppm/K in the range 0 ... +70 °C (32 ... +158 °F); according to IEC 60115-1 4.8
Maximum current	12.5 A continuous
Insulation class	600 V CAT II

## 9.9 Wiring Accessories

### 9.9.1 Standard Delivery Scope

The following three articles belong to the standard delivery scope of a *CMC 256* test set. They can, however, also be ordered separately.

#### 1. Flexible test lead



**Order number: VEHK0112**

2 m (6 ft.) test lead to connect the *CMC 256* output to other safety sockets of, for example, amplifiers, test objects or to banana adapters in control cabinets.

Specification: 1000 V/32 A

Amount supplied: 6 x red, 6 x black

#### 2. Flexible jumper



**Order number: VEHZ0009**

Flexible jumper to connect current outputs in parallel (up to 32 A) or to short-out the neutrals of binary inputs.

Specification: 1000 V/32 A

Amount supplied: 4 x black

### 3. Flexible terminal adapter



**Order number: VEHS0009**

Flexible terminal adapter to connect to screw-clamp terminals.

Specification: 1000 V/32 A

Amount supplied: 12 pieces

### 9.9.2 Optional CMC Wiring Accessory Package

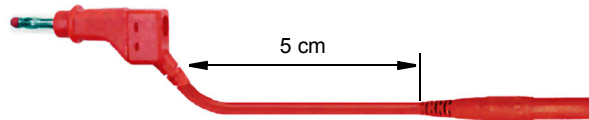
Figure 9-25:  
The CMC Wiring  
Accessory Package



**Order number: VEHZ0060**

The CMC Wiring Accessory Package contains the following s:

### 1. Flexible test lead adapter



5 cm (2") test lead adapter with retractable sleeve to connect the *CMC 256* output to non-safety sockets in combination with a regular flexible 2 m (6 ft.) test lead as shown at section 9.9.1.

Specification: 600 V/32 A

Amount: 6 x red, 6 x black

### 2. Flexible jumper



Flexible jumper to connect current outputs in parallel (up to 32 A) or to short-out the neutrals of binary inputs. Identical to article of standard delivery scope listed under 9.9.1.

Specification: 1000 V/32 A

Amount: 4 x black

### 3. Crocodile clamp



Crocodile clamps for secondary side to connect to pins or screw bolts.

Specification: 1000 V/32 A

Amount: 4 x red, 4 x black



#### 4. Flexible terminal adapter



Flexible terminal adapter to connect to screw-clamp terminals. Identical to article of standard delivery scope listed under 9.9.1.

Specification: 1000 V/32 A

Amount: 12 pieces

#### 5. M4 (0.15") Cable Lug Adapters



Cable lug adapters for M4 (0.15") screws to connect regular test leads to screw-clamp terminals of SEL/ABB/GE relays (and others).

Specification: 1000 V/20 A

Amount: 20 pieces

#### 6. M5 (0.2") Cable Lug Adapters



Cable lug adapters for M5 (0.2") screws to connect regular test leads to screw-clamp terminals of SEL/ABB/GE relays (and others).

Specification: 1000 V/20 A

Amount: 10 pieces

#### 7. Cable Tie (Velcro fastener)



Cable Tie (Velcro fastener), length 150 mm (6"), black.

Amount: 10 pieces

## 9.10 Ordering Information

This section lists the order numbers for optional equipment of the *CMC 256* test set.

Figure 9-26:  
Connection cables I

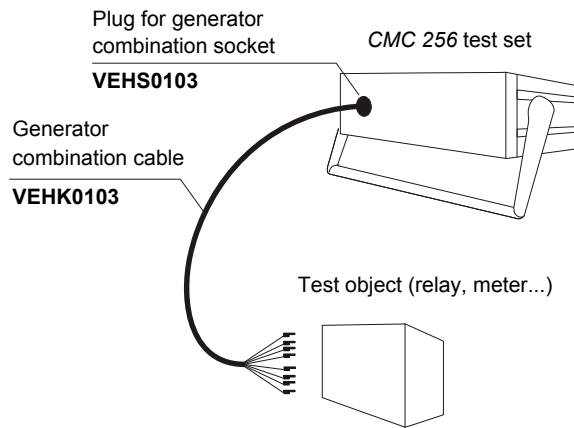


Figure 9-27:  
Connection cables II

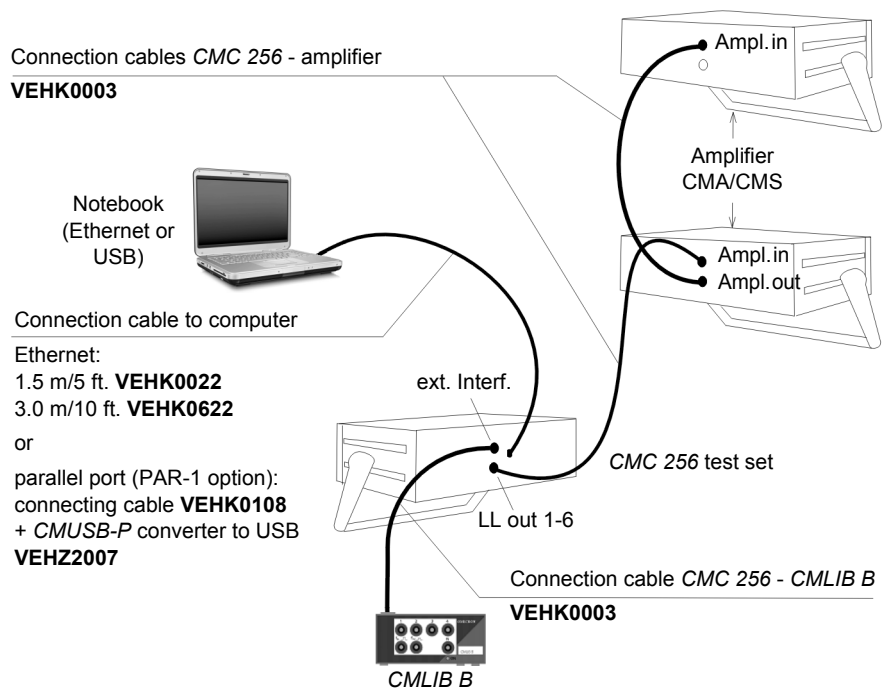


Table 9-5:  
Order numbers overview

Article		Order no.
<b>CMC 256plus options (factory upgrade)</b>		
PAR-1	CMC 256 with parallel port (→ section 6.11)	VEHO2702
LLO-2	Low level outputs LL out 7 - 12 (→ section 6.12)	VEHO2704
FL-6	Constraints the maximum output frequency to 599 Hz (→ section 2.1)	VEHO0599
<b>Amplifiers (→ section 9.1)</b>		
CMA 156	Current amplifier (6×25 A)	VEHV1010
CMS 156	Voltage/current amplifier (3×250 V, 3×25 A)	VEHV1030
<b>CMControl-6 (→ section 9.2)</b>		
CMControl-6; upgrade for an existing <i>CMC 256plus</i> (includes soft bag VEHP0014)		VEHO2806
CMControl-6; add-on for a new <i>CMC 256plus</i>		VEHO2805
<b>Binary input/output extensions (→ section 9.3)</b>		
CMB IO-7	Basic unit with 1×INP1-24, 1×OUT1-16 . Requires the PAR-1 option	VE000700
INP1-24	Binary input module (24 inputs, 0 ... 300 V)	VEHZ0710
OUT1-16	Binary output module (16 relay outputs)	VEHZ0720
OUT2-16	Binary solid state output module (16 MOSFET outputs)	VEHZ0750
Module connector for <i>CMB IO-7</i> input/output modules		VEHZ0740
<b>CMUSB-P (→ section 9.4)</b>		
Converter for controlling a <i>CMC 256</i> with the parallel port PAR-1 option by a computer with an USB port (requires a connection cable <i>CMC 256</i> parallel port to <i>CMUSB-P</i> converter. VEHK0108; see <b>Cables</b> below)		VEHZ2007
<b>CMIRIG-B Interface box (→ section 9.5.2)</b>		
CMIRIG-B	Interface box incl. all accessories	VEHZ1150
CMIRIG-B	Interface box	VEHZ1151
Connection cable <i>CMIRIG-B</i> ↔ <i>CMC 256</i>		VEHK0003

Article	Order no.
<b>CMGPS Synchronization unit</b> (→ section 9.5.1) Consisting of: <ul style="list-style-type: none"> <li>- <i>CMGPS</i> synchronization unit</li> <li>- antenna</li> <li>- 15 m antenna cable</li> <li>- power supply unit</li> <li>- 16-pole LEMO cable CMC-CMGPS</li> <li>- carrying bag.</li> </ul>	VEHZ3000
2 × 20 m antenna extension cable and SMA adapter	VEHZ3003
<b>100TX to 100FX-SC Converter</b> (→ section 9.6) Converter for data transfer from a 10/100Base-TX copper to a fiber interface	VEHZ0021
<b>Current clamp</b> (→ section 9.7) <i>C-PROBE1</i> Current clamp (10/80 A range, DC...10 kHz)	VEHZ4000
<b>Meter testing accessories</b>	
<i>OSH256</i> Passive scanning head, suction and adhesive fixation (→ section 9.8.1)	VEHZ2006
<i>IFB256</i> Interface Box for scanning head <i>OSH256</i> ; used for relay testing when binary information originates from a relay's LED (→ section 9.8.2)	VEHZ1152
<i>TK 326</i> Active and passive scanning head, mechanical fixation (→ section 9.8.3)	VEHZ2008
<i>TVS 6.15/1</i> Passive scanning head, magnetic fixation (→ section 9.8.4)	VEHZ2004
Adapter cable for scanning heads (→ section 9.8.5)	VEHK0010
<i>CMLIB B</i> Interface box for <ul style="list-style-type: none"> <li>- testing with reference meters</li> <li>- accessing the transistor outputs</li> </ul> (→ section 9.8.6)	VEHZ1102

Article	Order no.
<b>Meter testing accessories (cont.)</b>	
<i>CMLIB A</i> Interface box to - connect non-OMICRON amplifiers - tap the analog low level signal outputs of an amplifier	VEHZ1101
<i>CMLIB A</i> cable BNC to BNC	VEHK0008
<i>CMLIB A</i> cable BNC to 4 mm banana (→ section 9.8.7)	VEHK0005
<i>CPOL</i> Polarity Tester (→ section 9.8.8)	VEHZ0645
Connection cable for REF 54x Relays (ABB) with low level signal inputs (→ section 9.8.9)	VEHK0120
<i>C-Shunt</i> Precision shunts for current measurements - <i>C-Shunt 1</i> : 0.001 Ω - <i>C-Shunt 10</i> : 0.01 Ω (→ section 9.8.10)	VEHZ0080 VEHZ0081
<b>Connectors</b>	
Plug for generator combination socket (→ section 5.1.1)	VEHS0103
<b>Cables</b>	
Ethernet cable 1.5 m/5 ft	VEHK0022
Ethernet cable 3.0 m/10 ft	VEHK0622
Connection cable <i>CMC 256</i> parallel port (PAR-1 option) to <i>CMUSB-P</i> converter	VEHK0108
Connection cable <i>CMC 256</i> to amplifier, <i>CMLIB A/B</i> or <i>CMGPS</i>	VEHK0003
Generator combination cable	VEHK0103

Article	Order no.
<b>Wiring accessories</b> (→ section 9.9)	
Flexible test lead 1000 V/32 A, 6 x red, 6 x black	VEHK0112
CMC Wiring Accessory Package	VEHZ0060
containing the following items	
1. Flexible test lead with retractable sleeve, 600 V/32 A, 6 x red, 6 x black	
2. Flexible jumper, 600 V/32 A, 4 x black	
3. Crocodile clamps, 1000 V/32 A, 4 x red, 4 x black	
4. Flexible terminal adapter, 1000 V/32 A, black, 12 pieces	
5. M4 (0.15") Cable Lug Adapters, 1000 V/20 A, 20 pieces	
6. M5 (0.2") Cable Lug Adapters, 1000 V/20 A, 10 pieces	
7. Cable Tie (Velcro fastener), length 150 mm (6"), 10 pieces	

Article	Order no.
<p>Heavy-duty transport case with wheels and extendable handle for the <i>CMC 256plus</i> test set with or without CMControl-6, for <i>CMB IO-7</i>, and for CMA or CMS amplifiers.</p> 	<p>VEHP0021</p>
<p>Soft bag for <i>CMC 256plus</i> test set</p> <p>Soft bag for <i>CMC 256plus</i> test set with attached CMControl-6</p> 	<p>VEHP0012</p> <p>VEHP0014</p>





# APPENDIX

## The OMICRON Bootloader software

The OMICRON Bootloader software includes software parts developed by:

- Intel Corporation (IXP400 SW Release version 2.3)
- Intrinsic Software (Intrinsic Bootloader)
- Swedish Institute of Computer Science, Adam Dunkels (lwIP TCP/IP stack)
- Mark Adler (puff - decompress the deflate data format)
- Jean-loup Gailly and Mark Adler ("zlib" general purpose compression library)

The following copyright notices reproduce entirely the copyright notices provided by the source code owners.

### IXP400 SW Release version 2.3

Copyright (c) 2001-2005, Intel Corporation. All rights reserved.

Redistribution and use in source and binary forms, with or without modification, are permitted provided that the following conditions are met:

1. Redistributions of source code must retain the above copyright notice, this list of conditions and the following disclaimer.
2. Redistributions in binary form must reproduce the above copyright notice, this list of conditions and the following disclaimer in the documentation and/or other materials provided with the distribution.
3. Neither the name of the Intel Corporation nor the names of its contributors may be used to endorse or promote products derived from this software without specific prior written permission.

This software is provided by the copyright holders and contributors "as is" and any express or implied warranties, including, but not limited to, the implied warranties of merchantability and fitness for a particular purpose are disclaimed. In no event shall the copyright owner or contributors be liable for any direct, indirect, incidental, special, exemplary, or consequential damages (including, but not limited to, procurement of substitute goods or services; loss of use, data, or profits; or business interruption) however caused and on any theory of liability, whether in contract, strict liability, or tort (including negligence or otherwise) arising in any way out of the use of this software, even if advised of the possibility of such damage.

### Intrinsic Bootloader

Copyright (c) 2001-2002, Intrinsic Software. All rights reserved.

Redistribution and use in source and binary forms, with or without modification, are permitted provided that the following conditions are met:

1. Redistributions of source code must retain the above copyright notice, this list of conditions and the following disclaimer.
2. Redistributions in binary form must reproduce the above copyright notice, this list of conditions and the following disclaimer in the documentation and/or other materials provided with the distribution.

3. All advertising materials mentioning features or use of this software must display the following acknowledgement: This product includes software developed by Intrinsyc Software.
4. The name of Intrinsyc may not be used to endorse or promote products derived from this software without specific prior written permission.

This software is provided by Intrinsyc software and contributors "as is" and any express or implied warranties, including, but not limited to, the implied warranties of merchantability and fitness for a particular purpose are disclaimed. In no event shall Intrinsyc software be liable for any direct, indirect, incidental, special, exemplary, or consequential damages (including, but not limited to, procurement of substitute goods or services; loss of use, data, or profits; or business interruption) however caused and on any theory of liability, whether in contract, strict liability, or tort (including negligence or otherwise) arising in any way out of the use of this software, even if advised of the possibility of such damage.

### **lwIP TCP/IP stack**

Author: Adam Dunkels <adam@sics.se>

Copyright (c) 2001, 2002 Swedish Institute of Computer Science. All rights reserved.

Redistribution and use in source and binary forms, with or without modification, are permitted provided that the following conditions are met:

1. Redistributions of source code must retain the above copyright notice, this list of conditions and the following disclaimer.
2. Redistributions in binary form must reproduce the above copyright notice, this list of conditions and the following disclaimer in the documentation and/or other materials provided with the distribution.
3. The name of the author may not be used to endorse or promote products derived from this software without specific prior written permission.

This software is provided by the author "as is" and any express or implied warranties, including, but not limited to, the implied warranties of merchantability and fitness for a particular purpose are disclaimed. In no event shall the author be liable for any direct, indirect, incidental, special, exemplary, or consequential damages (including, but not limited to, procurement of substitute goods or services; loss of use, data, or profits; or business interruption) however caused and on any theory of liability, whether in contract, strict liability, or tort (including negligence or otherwise) arising in any way out of the use of this software, even if advised of the possibility of such damage.

### **puff (Mark Adler)**

This software is provided 'as-is', without any express or implied warranty. In no event will the author be held liable for any damages arising from the use of this software.

Permission is granted to anyone to use this software for any purpose, including commercial applications, and to alter it and redistribute it freely, subject to the following restrictions:

1. The origin of this software must not be misrepresented; you must not claim that you wrote the original software. If you use this software in a product, an acknowledgment in the product documentation would be appreciated but is not required.
2. Altered source versions must be plainly marked as such, and must not be misrepresented as being the original software.
3. This notice may not be removed or altered from any source distribution.

Mark Adler <madler@alumni.caltech.edu>

**zlib (Jean-loup Gailly and Mark Adler)**

Copyright (C) 1995-2002 Jean-loup Gailly and Mark Adler.

This software is provided 'as-is', without any express or implied warranty. In no event will the authors be held liable for any damages arising from the use of this software.

Permission is granted to anyone to use this software for any purpose, including commercial applications, and to alter it and redistribute it freely, subject to the following restrictions:

1. The origin of this software must not be misrepresented; you must not claim that you wrote the original software. If you use this software in a product, an acknowledgment in the product documentation would be appreciated but is not required.
2. Altered source versions must be plainly marked as such, and must not be misrepresented as being the original software.
3. This notice may not be removed or altered from any source distribution.

Mark Adler            <madler@alumni.caltech.edu>

Jean-loup Gailly    <jloup@gzip.org>

The data format used by the zlib library is described by RFCs (Request for Comments) 1950 to 1952 in the files ftp://ds.internic.net/rfc/rfc1950.txt (zlib format), rfc1951.txt (deflate format) and rfc1952.txt (gzip format).



# Contact Information / Technical Support

## North and South America

OMICRON electronics Corp. USA

12 Greenway Plaza, Suite 1510

Houston, TX 77046, USA

Phone: +1 713 830-4660 or 1 800 *OMICRON*

E-Mail: [techsupport@omicronusa.com](mailto:techsupport@omicronusa.com)

Web: <http://www.omicronusa.com>

## Asia, Pacific

OMICRON electronics Asia Ltd.

Suite 2006, 20/F, Tower 2

The Gateway, Harbour City

Kowloon, Hong Kong S.A.R.

Phone: +852 2634 0377

E-Mail: [support@asia.omicron.at](mailto:support@asia.omicron.at)

Web: <http://www.omicron.at>

## Europe, Africa, Middle East

OMICRON electronics GmbH

Oberes Ried 1

6833 Klaus, Austria

Phone: +43 5523 507-333

E-Mail: [support@omicron.at](mailto:support@omicron.at)

Web: <http://www.omicron.at>

For addresses of OMICRON offices with customer service centers, regional sales offices or offices for training, consulting and commissioning, please see the **Contact** section of our Web site <http://www.omicron.at>.



# INDEX

## Numerics

599 Hz restriction..... 13, 43, 58, 139

## A

accessories  
 adapter cable for scanning heads ..... 128  
 CMA/S current/voltage amplifiers ..... 113  
 CMB IO-7 ..... 115  
 CMGPS ..... 118  
 CMIRIG-B ..... 120  
 CMLIB B ..... 129  
 CMLIB-A ..... 130  
 CMLIB-B ..... 129  
 CMUSB-P converter ..... 115, 139  
 connecting cables ..... 134  
 C-PROBE1 ..... 123  
 C-Shunt ..... 133  
 ordering information ..... 138  
 wiring accessories ..... 134

accuracy  
 AC measurements ..... 80  
 amplitude accuracy of amplifiers ..... 113  
 AUX DC supply ..... 67  
 CMGPS ..... 118  
 CMIRIG-B ..... 120  
 DC current measurement input ..... 73  
 DC voltage measurement input ..... 73  
 frequency measurement ..... 86  
 LL outputs (SELV) ..... 63  
 output power ..... 61  
 phase measurement ..... 84  
 power measurement ..... 87  
 signal generation ..... 28

active power calculation ..... 87

address, OMICRON addresses ..... 149

altitude, max. altitude for operation ..... 76

amplifier  
 CMA current amplifier ..... 113  
 CMS voltage amplifier ..... 113  
 current amplifier (output) of CMC 256plus ..... 22  
 voltage amplifier (output) of CMC 256plus ..... 21

amplifiers  
 ordering information ..... 139

apparent power calculation ..... 87

## B

binary inputs  
 general data ..... 68

binary outputs  
 binary output relays 1-4 ..... 66  
 LL binary outputs ..... 64

## C

calibration  
 valid period of factory calibration ..... 41

CAN/CSA  
 certified safety standards ..... 77

CE  
 certified safety standards ..... 77

cleaning of CMC 256plus ..... 76

CMB IO-7 ..... 115

CMControl ..... 114

CMGPS ..... 118  
 ordering information ..... 140

CMIRIG-B ..... 120  
 ordering information ..... 139

CMLIB B ..... 129

CMLIB-A ..... 130

CMUSB-P converter ..... 115, 117, 139

compliance voltage  
 typically allowed c.v. to ensure continuous  
 operation ..... 54

connecting cables  
 how to use safely ..... 14  
 ordering information ..... 138

contact information  
 OMICRON addresses ..... 149

continuous operation  
 100 % duty cycle ..... 46  
 allowed compliance voltage to ensure c.o. .... 54

converter for fiber optics ..... 122

counter inputs 100 kHz (LL) ..... 71

C-PROBE1  
 ordering information ..... 140

C-Shunt (accessory) ..... 133

**C**

current  
 max. input current INPUT IDC..... 73  
 max. input current INPUT VDC ..... 73  
 current clamp C-PROBE1..... 123

**D**

DC current measurement input..... 73  
 DC measurement (ANALOG DC INPUT) ..... 73  
 DC voltage measurement input ..... 73  
 debouncing input signals ..... 70  
 deglitching input signals..... 70  
 dimensions of CMC 256plus..... 76  
 duty cycle  
 100 % continuous operation..... 46  
 duty cycles  
 for different loads and configurations ..... 46

**E**

ECM-compatibility..... 77  
 electromagnetic compatibility (EMC) ..... 77  
 e-mail  
 OMICRON addresses ..... 149  
 EN  
 certified safety standards ..... 77  
 Ethernet  
 Power over Ethernet..... 74  
 Ethernet cables  
 ordering information ..... 138  
 external interface (ext.Interf.)..... 64

**F**

fiber optics ..... 122  
 FL-6 option (599 Hz restriction) ..... 13, 43, 58, 139

frequency  
 output accuracy ..... 43  
 output drift..... 43  
 output range settings ..... 43  
 output resolution ..... 43  
 front panel components of CMC 256plus..... 29  
 front panel control CMControl ..... 114  
 fuse  
 changing the ..... 10  
 type..... 41

**G**

generator combination socket  
 ordering information ..... 138  
 voltage & current outputs..... 32

**H**

hotline ..... 149  
 housing specs of CMC 256plus ..... 76  
 humidity, relative ..... 76

**I**

IEC  
 certified safety standards..... 77  
 impedance  
 max. input impedance INPUT IDC ..... 73  
 max. input impedance INPUT VDC..... 73  
 increasing output power (operating modes) ..... 99  
 inputs  
 analog DC input UDC/IDC..... 25  
 binary inputs 1-10 ..... 68  
 counter input 100 kHz (LL)..... 71  
 DC measurement ..... 73  
 DC measurement (ANALOG DC INPUT) ..... 73  
 ISO9001  
 certified safety standards..... 77



---

**L**

- LL out (SELV low level outputs)..... 62
- LLO-2 option..... 98, 139

---

**M**

- measurement range
  - I<sub>DC</sub> measurement input..... 73
  - U<sub>DC</sub> measurement input ..... 73
- meter testing
  - CMLIB B..... 129
  - ordering information for accessories ..... 140, 141

---

**N**

- nominal mains current ..... 41

---

**O**

- operating temperature of CMC 256 ..... 76
- optical scanning heads
  - accessories ..... 126
- option
  - EnerLyzer measurement option ..... 78
  - LLO-2 ..... 98, 139
  - PAR-1 ..... 97, 139
- options
  - for CMC 256 (overview) ..... 12
- ordering information for CMC 256plus accessories.. 138
- OSH256
  - scanning head..... 124
- output power
  - per phase when group A || group B..... 56
  - voltage outputs (3-phase & single phase)..... 58
- outputs
  - current output groups A & B ..... 45
  - low-level outputs (LL out) ..... 62
  - parallel connection CURRENT A || CURRENT B. 55
  - voltage (technical data) ..... 58
- overheating
  - of current or voltage amplifier ..... 111

- overload warning
  - current amplifier..... 22
  - voltage amplifier ..... 21

---

**P**

- PAR-1 option (parallel port)..... 97, 139
- parallel connection CURRENT A || CURRENT B ..... 55
- phase
  - output error ..... 43
  - output range ..... 43
  - output resolution ..... 43
- PoE (Power over Ethernet)..... 74
- power
  - active power calculation ..... 87
  - apparent power calculation..... 87
  - reactive power calculation ..... 87
  - weak mains supply and output power (relation).. 61
- power supply range of CMC 256plus..... 27

---

**R**

- reactive power calculation ..... 87
- relative humidity ..... 76
- resolution
  - current outputs..... 45, 55
  - LL out 1-6 ..... 63
  - phase output..... 43
  - voltage outputs ..... 58

---

## S

safety	
certified safety standards .....	77
instructions .....	8
use of connecting cables.....	14
scanning heads	
accessories .....	126
ordering information .....	140, 141
self-test of hardware .....	18
SELV	
low level outputs 1-6.....	62
optional connector LL out 7-12.....	12, 98
shock and vibration (technical data) .....	76
shunt C-Shunt.....	133
shutdown due to overheating.....	111
signal generation .....	28
standards	
certified safety standards .....	77
storage temperature .....	76
supply voltage and output power (relation).....	61
synchronization via GPS.....	38, 118
synchronized operation.....	43
system components of CMC 256plus .....	13

---

## T

Technical Support.....	149
temperature	
operating temperature of CMC 256.....	76
storage temperature .....	76
temperature drift of output signals .....	43
test	
hardware self-test.....	18
test leads	
accessories .....	134
Test Universe software .....	7
TK 326	
scanning head .....	126
TVS 6.15/1	
scanning head .....	127

---

## U

UL	
certified safety standards.....	77

---

## V

vibration .....	76
voltage	
max. input voltage INPUT VDC .....	73
voltage outputs (technical data) .....	58

---

## W

weak mains supply and output power (relation) .....	61
Web site	
OMICRON Web site .....	149
weight of CMC 256plus.....	76
wiring accessory package (ordering information) ....	135